



MODEL:

**AFL3-W15C/W19C/W22C-ULT5**

Flat Bezel Panel PC with Intel® Core™ i5-8365UE CPU,  
Touchscreen, Four USB 3.2 Gen 2, Dual PoE GbE LAN,  
RS-232/422/485, Bluetooth, Wi-Fi 802.11a/b/g/n/ac and RoHS

## User Manual

# Revision

---

<b>Date</b>	<b>Version</b>	<b>Changes</b>
June 8, 2022	1.03	Updated for the R11 version of the AFL3-W19C-ULT5-i5 (changed LCD brightness)
November 29, 2021	1.02	Added Windows 11 support in Table 1-2
February 22, 2021	1.01	Modified LVDS connector pinouts (Table 6-6)
February 6, 2020	1.00	Initial release

# Safety Instructions

---

- en** Warning! Read the user manual before connecting the system to the power source.
- de** Vorsicht! Bitte lesen Sie die Bedienungsanleitung, bevor Sie das System an eine Stromquelle anschließen.
- fr** Attention! Avant de brancher le système à la source d'alimentation, consultez le mode d'emploi.
- it** Avvertenza! Consultare il manuale utente prima di collegare il sistema all'alimentatore.
- es** Atención! Lea atentamente este manual del usuario antes de operar la fuente de alimentación.
- zh** 警告！在將系統連接到電源之前，請仔細閱讀使用手冊。
- cn** 警告！在將系統連接到電源之前，請仔細閱讀使用手冊。
- 

- en** Warning! To prevent the system from overheating, do not operate it in an area that exceeds the maximum operating temperature described in the user manual.
- de** Vorsicht! Um eine Überhitzung des Systems zu vermeiden, betreiben Sie es ausschließlich im zulässigen Betriebstemperaturbereich. Dieser ist in der Bedienungsanleitung vermerkt.
- fr** Attention! Pour éviter la surchauffe du système, ne l'utilisez pas dans une zone dont la température dépasse les limites décrits dans le mode d'emploi.
- it** Avvertenza! Per evitare che il sistema si surriscaldi, non utilizzarlo in aree che superino la temperatura massima d'esercizio descritta nel manuale utente.
- es** Atención! Para evitar el excesivo calentamiento del sistema, no opere en las condiciones de temperatura superior a lo recomendado en este manual del usuario.
- zh** 警告！為防止系統過熱，不要在使用手冊上記載的產品工作溫度範圍之外操作此系統。
- cn** 警告！為防止系統過熱，不要在使用手冊上記載的產品工作溫度範圍之外操作此系統。
-

- en** Warning! Use only the adapter and power cord approved for this system. Use of another type of adapter may risk fire or explosion. Please refer to the user manual for the power adapter specifications.
- de** Vorsicht! Nur zugelassene Netzteile und Netzkabel dürfen verwendet werden. Die Benutzung von anderen Netzteilen kann einen Brand oder eine Explosion zur Folge haben. Prüfen Sie die jeweiligen Spezifikationen in der Bedienungsanleitung.
- fr** Attention! Utilisez exclusivement le câble d'alimentation et l'adaptateur homologués pour ce système. L'utilisation d'un autre type d'adaptateur risquerait de provoquer un incendie ou une explosion. Veuillez référer au mode d'emploi pour les spécifications de l'adaptateur d'alimentation.
- it** Avvertenza! Utilizzare solo l'adattatore e il cavo di alimentazione approvati per questo sistema. L'uso di un altro tipo di adattatore può causare rischio d'incendio o esplosione. Si prega di fare riferimento al manuale utente per le specifiche sull'alimentazione.
- es** Atención! Utilice solamente el adaptador de corriente alterna (CA) con Marcas Conformidad otorgadas. Cualquier otro adaptador no otorgado aumenta el riesgo de explosión o incendio. Por favor consulte el manual del usuario para las especificaciones del adaptador de alimentación.
- zh** 警告！只能使用經過認證、適用於本系統的電源變壓器與電源線。使用不適用的電源變壓器將可能導致火災或爆炸。電源變壓器規格請參考使用手冊。
- cn** 警告！只能使用经过认证，适用于本系统的电源适配器与电源线。使用不适用的电源适配器将可能导致火灾或爆炸。电源适配器规格请参考使用手冊。

- 
- en** Warning! Ultimate disposal of this product should be handled according to all national laws and regulations.
- de** Vorsicht! Die Entsorgung dieses Produkts sollte gemäß allen Bestimmungen und Gesetzen des Landes erfolgen.
- fr** Attention! La mise au rebut ou le recyclage de ce produit sont généralement soumis aux lois et/ou directives de respect de l'environnement. Renseignez-vous auprès de l'organisme compétent.
- it** Avvertenza! Lo smaltimento di questo prodotto deve essere eseguito secondo le leggi e i regolamenti locali.
- es** Atención! La disposición final de residuos de este producto se debe cumplir con las normativas y leyes del país.
- zh** 警告！本產品的廢棄處理應根據該國家的法律和規章進行。
- cn** 警告！本产品的废弃处理应根据该国家的法律和规章进行。
-

# Copyright

---

## **COPYRIGHT NOTICE**

The information in this document is subject to change without prior notice in order to improve reliability, design and function and does not represent a commitment on the part of the manufacturer.

In no event will the manufacturer be liable for direct, indirect, special, incidental, or consequential damages arising out of the use or inability to use the product or documentation, even if advised of the possibility of such damages.

This document contains proprietary information protected by copyright. All rights are reserved. No part of this manual may be reproduced by any mechanical, electronic, or other means in any form without prior written permission of the manufacturer.

## **TRADEMARKS**

All registered trademarks and product names mentioned herein are used for identification purposes only and may be trademarks and/or registered trademarks of their respective owners.



# Manual Conventions

---



## **WARNING**

Warnings appear where overlooked details may cause damage to the equipment or result in personal injury. Warnings should be taken seriously.



## **CAUTION**

Cautionary messages should be heeded to help reduce the chance of losing data or damaging the product.



## **NOTE**

These messages inform the reader of essential but non-critical information. These messages should be read carefully as any directions or instructions contained therein can help avoid making mistakes.



## **HOT SURFACE**

This symbol indicates a hot surface that should not be touched without taking care.

# Table of Contents

<b>1 INTRODUCTION.....</b>	<b>1</b>
1.1 OVERVIEW.....	2
1.2 MODEL VARIATIONS .....	3
1.3 FEATURES.....	3
1.4 FRONT PANEL.....	4
1.5 BOTTOM PANEL .....	5
1.6 REAR PANEL .....	5
1.7 SYSTEM SPECIFICATIONS.....	6
1.8 DIMENSIONS.....	9
1.8.1 AFL3-W15C-ULT5 Dimensions.....	9
1.8.2 AFL3-W19C-ULT5 Dimensions.....	10
1.8.3 AFL3-W22C-ULT5 Dimensions.....	11
<b>2 UNPACKING .....</b>	<b>12</b>
2.1 UNPACKING.....	13
2.2 PACKING LIST .....	13
2.3 OPTIONAL ITEMS.....	14
<b>3 INSTALLATION .....</b>	<b>16</b>
3.1 ANTI-STATIC PRECAUTIONS.....	17
3.2 INSTALLATION PRECAUTIONS.....	17
3.3 INSTALLATION AND CONFIGURATION STEPS .....	18
3.4 REMOVING THE BACK COVERS .....	18
3.5 M.2 MODULE INSTALLATION.....	23
3.6 PCIe MINI MODULE INSTALLATION .....	25
3.7 HDD INSTALLATION.....	28
3.8 PoE PD MODULE INSTALLATION (OPTIONAL) .....	30
3.9 RS-232/422/485 SERIAL PORT (COM1) SELECTION .....	31
3.9.1 COM1 Pinouts .....	31
3.9.2 COM1 Pin 9 Selection .....	31
3.10 FLASH DESCRIPTOR SECURITY OVERRIDE.....	32

3.11 CLEAR CMOS.....	33
3.12 AT/ATX MODE SELECTION.....	34
3.12.1 AT Power Mode.....	34
3.12.2 ATX Power Mode.....	34
3.13 MOUNTING THE SYSTEM.....	35
3.13.1 Wall Mounting.....	35
3.13.2 Panel Mounting.....	38
3.13.3 Cabinet and Rack Installation.....	42
3.13.4 Arm Mounting.....	45
3.13.5 Stand Mounting.....	47
3.14 POWERING ON THE SYSTEM.....	48
3.15 RESET THE SYSTEM.....	49
3.16 SOFTWARE INSTALLATION.....	49
3.16.1 Driver Download.....	50
<b>4 BIOS SETUP.....</b>	<b>52</b>
4.1 INTRODUCTION.....	53
4.1.1 Starting Setup.....	53
4.1.2 Using Setup.....	53
4.1.3 Getting Help.....	54
4.1.4 Unable to Reboot after Configuration Changes.....	54
4.1.5 BIOS Menu Bar.....	54
4.2 MAIN.....	55
4.3 ADVANCED.....	56
4.3.1 CPU Configuration.....	57
4.3.2 PCH-FW Configuration.....	59
4.3.3 ACPI Settings.....	60
4.3.4 RTC Wake Settings.....	61
4.3.5 iWDD H/W Monitor.....	62
4.3.6 F81866 Super IO Configuration.....	63
4.3.6.1 Serial Port n Configuration.....	64
4.3.6.1.1 Serial Port 1 Configuration.....	64
4.3.6.1.2 Serial Port 2 Configuration.....	65
4.3.7 Serial Port Console Redirection.....	65
4.3.7.1 Legacy Console Redirection Settings.....	66



## AFL3-W15C/W19C/W22C-ULT5 Panel PC

4.3.7.2 Console Redirection Settings .....	67
4.3.8 USB Configuration.....	69
4.3.9 NVMe Configuration.....	70
4.3.10 IEI Feature.....	71
4.4 CHIPSET .....	72
4.4.1 System Agent (SA) Configuration .....	72
4.4.1.1 Memory Configuration .....	73
4.4.1.2 Graphics Configuration.....	74
4.4.2 PCH-IO Configuration .....	75
4.4.2.1 PCI Express Configuration .....	77
4.4.2.2 SATA And RST Configuration.....	78
4.5 SECURITY.....	80
4.6 BOOT.....	81
4.7 EXIT.....	83
<b>5 SYSTEM MAINTENANCE .....</b>	<b>85</b>
5.1 SYSTEM MAINTENANCE INTRODUCTION .....	86
5.2 ANTI-STATIC PRECAUTIONS.....	86
5.3 TURN OFF THE POWER.....	87
5.4 SO-DIMM MODULE REPLACEMENT.....	87
<b>6 INTERFACE CONNECTORS .....</b>	<b>89</b>
6.1 PERIPHERAL INTERFACE CONNECTORS.....	90
6.2 INTERNAL PERIPHERAL CONNECTORS .....	91
6.2.1 Audio Out Connector (AUDIO_OUT2).....	92
6.2.2 Battery Connector (BAT1) .....	92
6.2.3 Digital I/O Connector (DIO1) .....	92
6.2.4 Inverter Connector (INVERTER1).....	93
6.2.5 LVDS Connector (LVDS1) .....	93
6.2.6 M.2 A-Key Slot (M2_A1).....	94
6.2.7 M.2 M-key Slot (M2_M2).....	95
6.2.8 Microphone Connector (DMIC1) .....	96
6.2.9 PCIe Mini Connector, Full-size (MINI_PCIE1) .....	97
6.2.10 Power Button Connector (PW_BTN1).....	98
6.2.11 Power LED Connector (PW_LED1).....	98

6.2.12 SATA Connector (SATA1).....	98
6.2.13 SPI Flash Connector (JSP11).....	99
6.2.14 USB Connector (BT_USB1).....	99
6.2.15 USB Connector (TOUCH_USB1).....	99
6.2.16 USB Connector (RFID_USB1).....	100
6.2.17 USB Connector (WEBCAM_USB1).....	100
<b>6.3 EXTERNAL INTERFACE PANEL CONNECTORS.....</b>	<b>100</b>
6.3.1 Ethernet Connectors (LAN1, J1, J2).....	101
6.3.2 Power Connector (PWR3).....	101
6.3.3 HDMI Connector (HDMI1).....	102
6.3.4 RS-232/422/485 DB-9 Serial Port (COM1).....	102
6.3.5 RS-232 RJ-45 Serial Port (COM2).....	103
6.3.6 USB 3.2 Gen 2 Connectors (USB_CON1).....	103
<b>A REGULATORY COMPLIANCE .....</b>	<b>104</b>
<b>B SAFETY PRECAUTIONS .....</b>	<b>109</b>
B.1 SAFETY PRECAUTIONS.....	110
B.1.1 General Safety Precautions.....	110
B.1.2 Anti-static Precautions .....	111
B.1.3 Product Disposal.....	112
B.2 MAINTENANCE AND CLEANING PRECAUTIONS .....	113
B.2.1 Maintenance and Cleaning.....	113
B.2.2 Cleaning Tools.....	113
<b>C BIOS MENU OPTIONS.....</b>	<b>115</b>
<b>D WATCHDOG TIMER .....</b>	<b>118</b>
<b>E ERROR BEEP CODE.....</b>	<b>121</b>
E.1 PEI BEEP CODES.....	122
E.2 DXE BEEP CODES .....	122
<b>F HAZARDOUS MATERIALS DISCLOSURE.....</b>	<b>123</b>
F.1 RoHS II DIRECTIVE (2015/863/EU) .....	124
F.2 CHINA RoHS.....	125

# List of Figures

Figure 1-1: AFL3-W15C/W19C/W22C-ULT5 Flat Bezel Panel PC .....	2
Figure 1-2: Front View .....	4
Figure 1-3: Bottom Panel .....	5
Figure 1-4: AFL3-W15C-ULT5 Rear View .....	5
Figure 1-5: AFL3-W15C-ULT5 Dimensions (mm) .....	9
Figure 1-6: AFL3-W19C-ULT5 Dimensions (mm) .....	10
Figure 1-7: AFL3-W22C-ULT5 Dimensions (mm) .....	11
Figure 3-1: AFL3-W15C-ULT5 Back Cover Retention Screws .....	19
Figure 3-2: AFL3-W19C-ULT5 Back Cover Retention Screws .....	19
Figure 3-3: AFL3-W22C-ULT5 Back Cover Retention Screws .....	20
Figure 3-4: AFL3-W15C-ULT5 Metal Cover Retention Screws .....	21
Figure 3-5: AFL3-W19C-ULT5 Metal Cover Retention Screws .....	21
Figure 3-6: AFL3-W22C-ULT5 Metal Cover Retention Screws .....	21
Figure 3-7: Lift the Metal Cover .....	22
Figure 3-8: M.2 Module Slot Location .....	23
Figure 3-9: Inserting the M.2 Module into the Slot at an Angle .....	24
Figure 3-10: Securing the M.2 Module .....	24
Figure 3-11: PCIe Mini Module Slot Location .....	25
Figure 3-12: Removing the Retention Screw .....	26
Figure 3-13: Installing a PCIe Mini Module .....	26
Figure 3-14: Securing the PCIe Mini Module .....	27
Figure 3-15: HDD Bracket Retention Screws .....	28
Figure 3-16: HDD Retention Screws .....	29
Figure 3-17: HDD Installation .....	29
Figure 3-18: PoE Module Slot Location .....	30
Figure 3-19: COM1 Pin 9 Setting Jumper Location .....	32
Figure 3-20: Flash Descriptor Security Override Jumper Location .....	33
Figure 3-21: Clear CMOS Button Location .....	33
Figure 3-22: AT/ATX Switch Location .....	34
Figure 3-23: Wall-mounting Bracket .....	36
Figure 3-24: Chassis Support Screws .....	37

Figure 3-25: Secure the Panel PC .....	38
Figure 3-26: AFL3-W15C-ULT5 Cutout Dimensions.....	38
Figure 3-27: AFL3-W19C-ULT5 Cutout Dimensions.....	39
Figure 3-28: AFL3-W22C-ULT5 Cutout Dimensions.....	39
Figure 3-29: Panel Mounting Kit Installation .....	40
Figure 3-30: Securing Panel Mounting Brackets.....	41
Figure 3-31: Rack Mounting Kit Installation .....	43
Figure 3-32: Securing Rack Mounting Brackets.....	44
Figure 3-33: Install into a Rack/Cabinet .....	44
Figure 3-34: Arm Mounting Retention Screw Holes.....	46
Figure 3-35: Arm Mounting .....	46
Figure 3-36: Stand Mounting (Stand-A/Bxx).....	47
Figure 3-37: Powering On the System.....	48
Figure 3-38: Reset Button Location.....	49
Figure 3-39: IEI Resource Download Center.....	49
Figure 5-1: SO-DIMM module Location .....	87
Figure 5-2: SO-DIMM Installation .....	88
Figure 6-1: Main Board Layout Diagram .....	90

# List of Tables

Table 1-1: Model Variations .....	3
Table 1-2: System Specifications.....	8
Table 3-1: RS-232/422/485 Serial Port (COM1) Pinouts .....	31
Table 3-2: COM1 Pin 9 Setting Jumper Settings (JP5) .....	31
Table 3-3: Flash Descriptor Security Override Jumper Settings.....	32
Table 6-1: Peripheral Interface Connectors .....	91
Table 6-2: Audio Out Connector (AUDIO_OUT2) Pinouts .....	92
Table 6-3: Battery Connector (BAT1) Pinouts .....	92
Table 6-4: Digital I/O Connector (DIO1) Pinouts.....	92
Table 6-5: Inverter Connector (INVERTER1) Pinouts.....	93
Table 6-6: LVDS Connector (LVDS1) Pinouts.....	93
Table 6-7: M.2 A-Key Slot (M2_A1) Pinouts .....	95
Table 6-8: M.2 M-key Slot (M2_M2) Pinouts .....	96
Table 6-9: Microphone Connector (DMIC1) Pinouts .....	96
Table 6-10: Full-size PCIe Mini Connector (MINI_PCIE1) Pinouts .....	97
Table 6-11: Power Button Connector (PW_BTN1) Pinouts .....	98
Table 6-12: Power LED Connector (PW_LED1) Pinouts.....	98
Table 6-13: SATA Connector (SATA1) Pinouts .....	98
Table 6-14: SPI Flash Connector (JSPI1) Pinouts .....	99
Table 6-15: USB Connector (BT_USB1) Pinouts .....	99
Table 6-16: USB Connector (TOUCH_USB1) Pinouts.....	99
Table 6-17: USB Connector (RFID_USB1) Pinouts .....	100
Table 6-18: USB Connector (CAM_USB1) Pinouts.....	100
Table 6-19: Rear Panel Connectors .....	101
Table 6-20: Ethernet Connectors (LAN1, J1, J2) Pinouts.....	101
Table 6-21: Ethernet Connector LEDs.....	101
Table 6-22: Power Connector (PWR1) Pinouts.....	101
Table 6-23: HDMI Connector (HDMI1) Pinouts.....	102
Table 6-24: RS-232/422/485 DB-9 Serial Port (COM1) Pinouts.....	102
Table 6-25: RS-232 RJ-45 Serial Port (COM2) Pinouts.....	103
Table 6-26: USB 3.2 Gen 2 Connectors (USB_CON1, USB_CON2) Pinouts.....	103



# List of BIOS Menus

---

BIOS Menu 1: Main .....	55
BIOS Menu 2: Advanced .....	56
BIOS Menu 3: CPU Configuration .....	57
BIOS Menu 4: PCH-FW Configuration .....	59
BIOS Menu 5: ACPI Settings .....	60
BIOS Menu 6: RTC Wake Settings .....	61
BIOS Menu 7: iWDD H/W Monitor .....	62
BIOS Menu 8: F81866 Super IO Configuration .....	63
BIOS Menu 9: Serial Port n Configuration .....	64
BIOS Menu 10: Serial Port Console Redirection .....	65
BIOS Menu 11: Legacy Console Redirection Settings .....	66
BIOS Menu 12: Console Redirection Settings .....	67
BIOS Menu 13: USB Configuration .....	69
BIOS Menu 14: NVMe Configuration.....	70
BIOS Menu 15: IEI Feature .....	71
BIOS Menu 16: Chipset .....	72
BIOS Menu 17: System Agent (SA) Configuration .....	72
BIOS Menu 18: Memory Configuration.....	73
BIOS Menu 19: Graphics Configuration .....	74
BIOS Menu 20: PCH-IO Configuration .....	75
BIOS Menu 21: PCI Express Configuration .....	77
BIOS Menu 22: SATA and RST Configuration .....	78
BIOS Menu 23: Security .....	80
BIOS Menu 24: Boot .....	81
BIOS Menu 25: Exit.....	83

Chapter

1

# Introduction

---

## 1.1 Overview



**Figure 1-1: AFL3-W15C/W19C/W22C-ULT5 Flat Bezel Panel PC**

The AFL3-W15C/W19C/W22C-ULT5 series is a quad-core Intel® Core™ i5-8365UE powered flat bezel touchscreen panel PC with a rich variety of functions and peripherals. The flat-bezel design is ideal for easy and simplified integration into various applications.

The Intel® Core™ i5-8365UE is a System-on-Chip (SoC) that ensures optimal memory, graphics, and peripheral I/O support. The system comes with 4.0 GB of DDR4 SO-DIMM memory ensuring smooth data throughputs with reduced bottlenecks and fast system access.

One RS-232/422/485 serial port, one RS-232 serial port and four external USB 3.2 Gen 2 ports ensure simplified connectivity to a variety of external peripheral devices. Wi-Fi capabilities and three RJ-45 Ethernet connectors provide the system with smooth connection to an external LAN. Moreover, two of the Ethernet connectors are capable to support PoE by installing the optional PoE module.

## AFL3-W15C/W19C/W22C-ULT5 Panel PC

### 1.2 Model Variations

There are several models in the AFL3-W15C/W19C/W22C-ULT5 series. The model numbers and model variations are listed below.

Model	Size	Panel Spec.
<b>AFL3-W15C-ULT5-i5/P/PC/4G</b>	15.6"	300 cd/m <sup>2</sup> , 1366x768
<b>AFL3-W19C-ULT5-i5/P/PC/4G</b>	18.5"	400 cd/m <sup>2</sup> , 1366x768
<b>AFL3-W22C-ULT5-i5/P/PC/4G</b>	21.5"	250 cd/m <sup>2</sup> , 1920x1080

**Table 1-1: Model Variations**

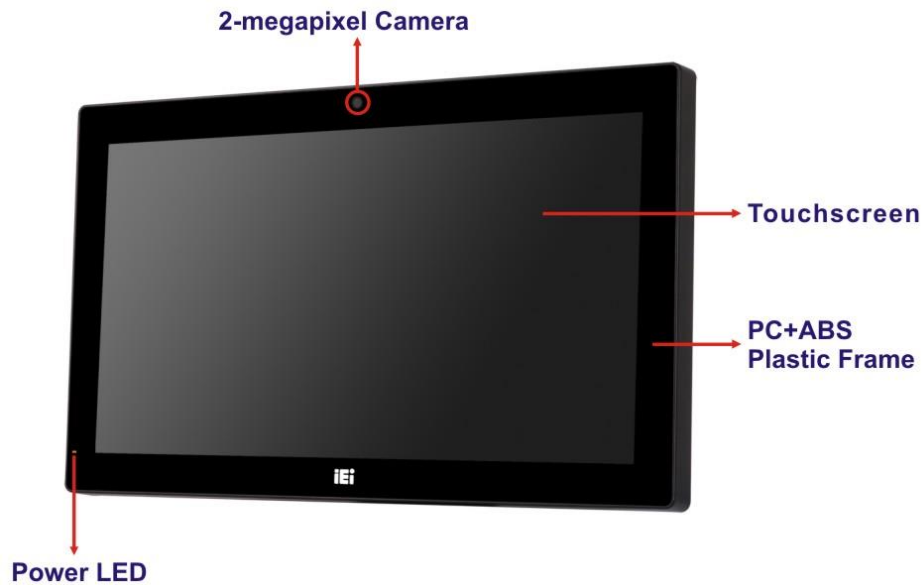
### 1.3 Features

The AFL3-W15C/W19C/W22C-ULT5 features are listed below:

- Flat-bezel LCD with LED backlight
- 8<sup>th</sup> generation Intel® Core™ i5-8365UE processor
- Preinstalled with 4 GB of DDR4 memory (system max. 32 GB)
- Anti-glare/anti-UV projected capacitive type touchscreen
- Wi-Fi 802.11a/b/g/n/ac high speed wireless and Bluetooth v4.1
- Three PCIe GbE RJ-45 connectors (two with PoE support)
- Two internal speakers
- Four USB 3.2 Gen 2 (10 Gb/s) ports
- One RS-232/422/485 serial port and one RS-232 serial port by D-sub 9 connectors; support Auto Flow Control (AFC) via RS-485
- Optional RFID reader
- Optional magnetic stripe card reader
- 12 V DC power input
- IP 64 compliant front panel

## 1.4 Front Panel

The front side of the AFL3-W15C/W19C/W22C-ULT5 is a flat-bezel panel with a TFT LCD screen surrounded by a PC/ABS plastic frame (**Figure 1-2**).



**Figure 1-2: Front View**

There is a power LED indicator located on the front panel. The status descriptions of the power LED indicator are listed below.

- **Off:** power cord not attached or power supply failure
- **Solid amber:** the system is connected to a power source and is ready to be turned on.
- **Solid green:** the system is turned on.



## AFL3-W15C/W19C/W22C-ULT5 Panel PC

### 1.5 Bottom Panel

The bottom panel of the AFL3-W15C/W19C/W22C-ULT5 has the following connectors and switches.

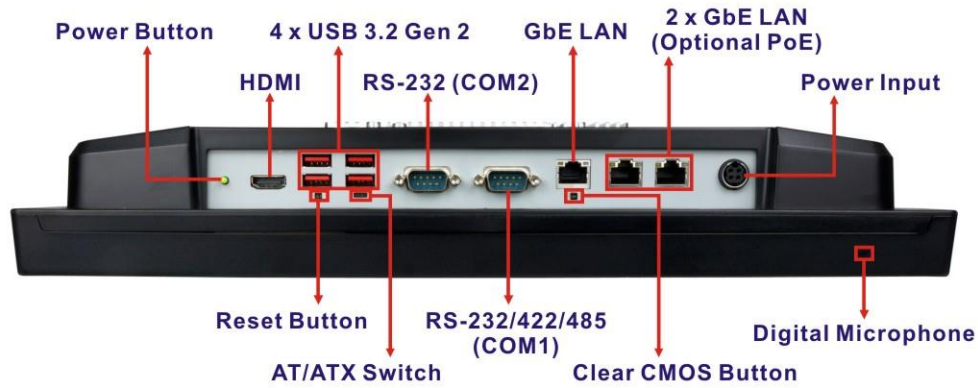


Figure 1-3: Bottom Panel

### 1.6 Rear Panel

The rear panel has two speakers and retention screw holes that support VESA mounting. The rear panel also has several retention screw holes for installing the optional barcode scanner and magnetic stripe card reader.

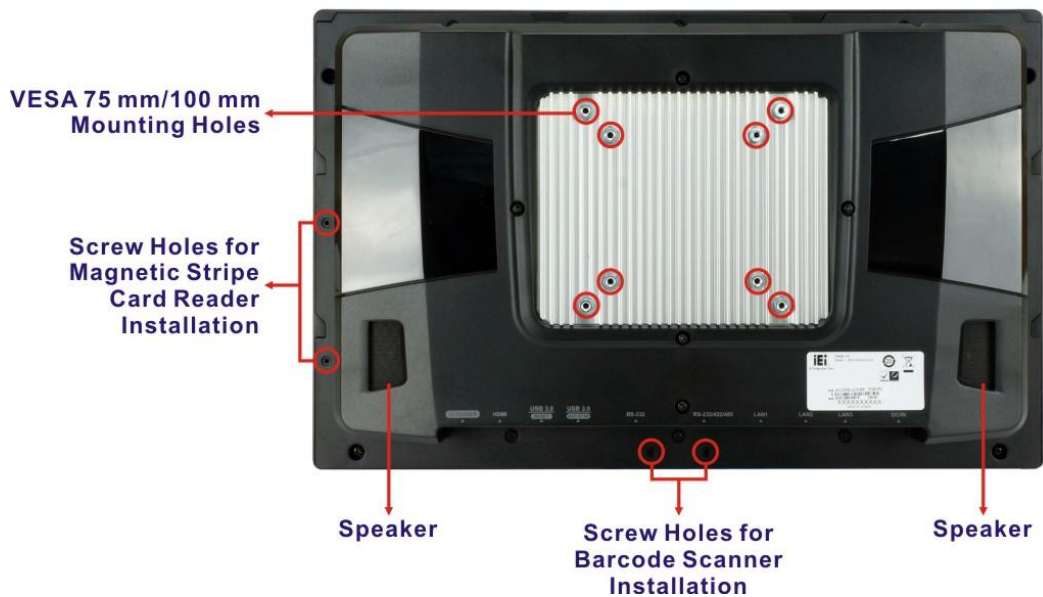


Figure 1-4: AFL3-W15C-ULT5 Rear View

## 1.7 System Specifications

The technical specifications for the AFL3-W15C/W19C/W22C-ULT5 systems are listed in **Table 1-2**.

Specification	AFL3-W15C-ULT5	AFL3-W19C-ULT5	AFL3-W22C-ULT5
<b>LCD Size</b>	15.6" (16:9)	18.5" (16:9)	21.5" (16:9)
<b>Max. Resolution</b>	1366 (W) x 768 (H)	1366 (W) x 768 (H)	1920 (W) x 1080 (H)
<b>Brightness (cd/m<sup>2</sup>)</b>	300	400	250
<b>Contrast Ratio</b>	500:1	1000:1	1000:1
<b>Viewing Angle (H-V)</b>	170° / 160°	170° / 160°	170° / 160°
<b>Backlight MTBF</b>	50,000 hrs	30,000 hrs	30,000 hrs
<b>Backlight</b>	LED	LED	LED
<b>Touchscreen</b>	Anti-glare/Anti-UV projected capacitive	Anti-glare/Anti-UV projected capacitive	Anti-glare/Anti-UV projected capacitive
<b>Touch Controller</b>	EETI EXC 3160	EETI EXC 3160	EETI EXC 3160
<b>CPU (SoC)</b>	Intel® Core™ i5-8365UE processor		
<b>Memory</b>	Two 260-pin DDR4 SO-DIMM slots (system max. 32 GB) One slot is preinstalled with a 4 GB memory module		
<b>Ethernet</b>	<b>LAN1, LAN2:</b> Intel® I211-AT PCIe GbE controllers <b>LAN3:</b> Intel® I219-LM PHY		
<b>PoE</b>	Optional IEEE802.3af/at/bt module via PCIe Mini slot		
<b>Storage</b>	One M.2 M-key slot (PCIe, SATA) for M.2 2280 module installation One 2.5" SATA 3Gb/s HDD bay		
<b>Audio</b>	Realtek ALC269 HD Audio codec		
<b>Internal Speaker</b>	Two 3 W		

## AFL3-W15C/W19C/W22C-ULT5 Panel PC

<b>Camera</b>	2-megapixel with low light function and digital microphone		
<b>Wireless &amp; Bluetooth</b>	802.11a/b/g/n/ac WLAN and Bluetooth v4.1 supported by the pre-installed M.2 2230 A+E-key WLAN module		
<b>Expansion</b>	One full-size PCIe Mini slot (PCIe, USB)		
<b>RFID Reader</b>	Mifare 13.56 MHz card reader (optional)		
<b>Card Reader</b>	Magnetic stripe card reader (optional)		
<b>Construction Material</b>	PC+ABS plastic		
<b>Thermal Design</b>	Fanless		
<b>VESA Mount</b>	75 mm x 75 mm 100 mm x 100 mm		
<b>Mounting</b>	Panel, wall, stand or arm mounting		
<b>Front Panel Color</b>	Black C		
<b>Net/Gross Weight</b>	4.5 kg / 6.5 kg	7.3 kg / 10 kg	8.3 kg / 11.3 kg
<b>Dimensions (W x H x D) (mm)</b>	396 x 250 x 64	470 x 290 x 70	528 x 336 x 68
<b>Operating Temperature</b>	-20°C ~ 50°C		
<b>Storage Temperature</b>	-20°C ~ 60°C		
<b>Humidity</b>	10% ~ 95% (non-condensing)		
<b>Power Supply</b>	96 W power adapter		
	<b>Input:</b>	100 V ~ 240 V AC, 50 Hz ~ 60 Hz	
	<b>Output:</b>	12 V DC	
<b>Power Requirement</b>	12 V DC, 8 A PoE IEEE802.3af/at/bt (redundancy, power load-sharing)		
<b>Power Consumption</b>	96 W		
<b>IP Level</b>	IP 64 compliant front panel		

<b>Safety/EMC</b>	CE, FCC Class A
<b>ErP</b>	ErP 2009/125/EC
<b>Supported OS</b>	Microsoft Windows 10 / Windows 11, Linux
<b>I/O Ports and Switches</b>	<ul style="list-style-type: none"> <li>1 x RS-232/422/485 serial port (DB-9 connector)</li> <li>1 x RS-232 serial port (DB-9 connector)</li> <li>2 x PoE GbE LAN* (RJ-45 connector)</li> <li>1 x GbE LAN (RJ-45 connector)</li> <li>4 x USB 3.2 Gen 2 (10 Gb/s) connectors</li> <li>1 x HDMI output connector</li> <li>1 x Power button</li> <li>1 x AT/ATX switch</li> <li>1 x Reset button</li> <li>1 x Clear CMOS button</li> <li>1 x 12 V DC input jack</li> </ul>
<p>* An IEI PoE module must be installed before start using the panel PC as a PoE powered device (PD). Refer <b>Section 3.8</b> to install the optional PoE module.</p>	

**Table 1-2: System Specifications**

**AFL3-W15C/W19C/W22C-ULT5 Panel PC**

**1.8 Dimensions**

The following sections list the dimensions of each model.

**1.8.1 AFL3-W15C-ULT5 Dimensions**

The AFL3-W15C-ULT5 dimensions are shown below.

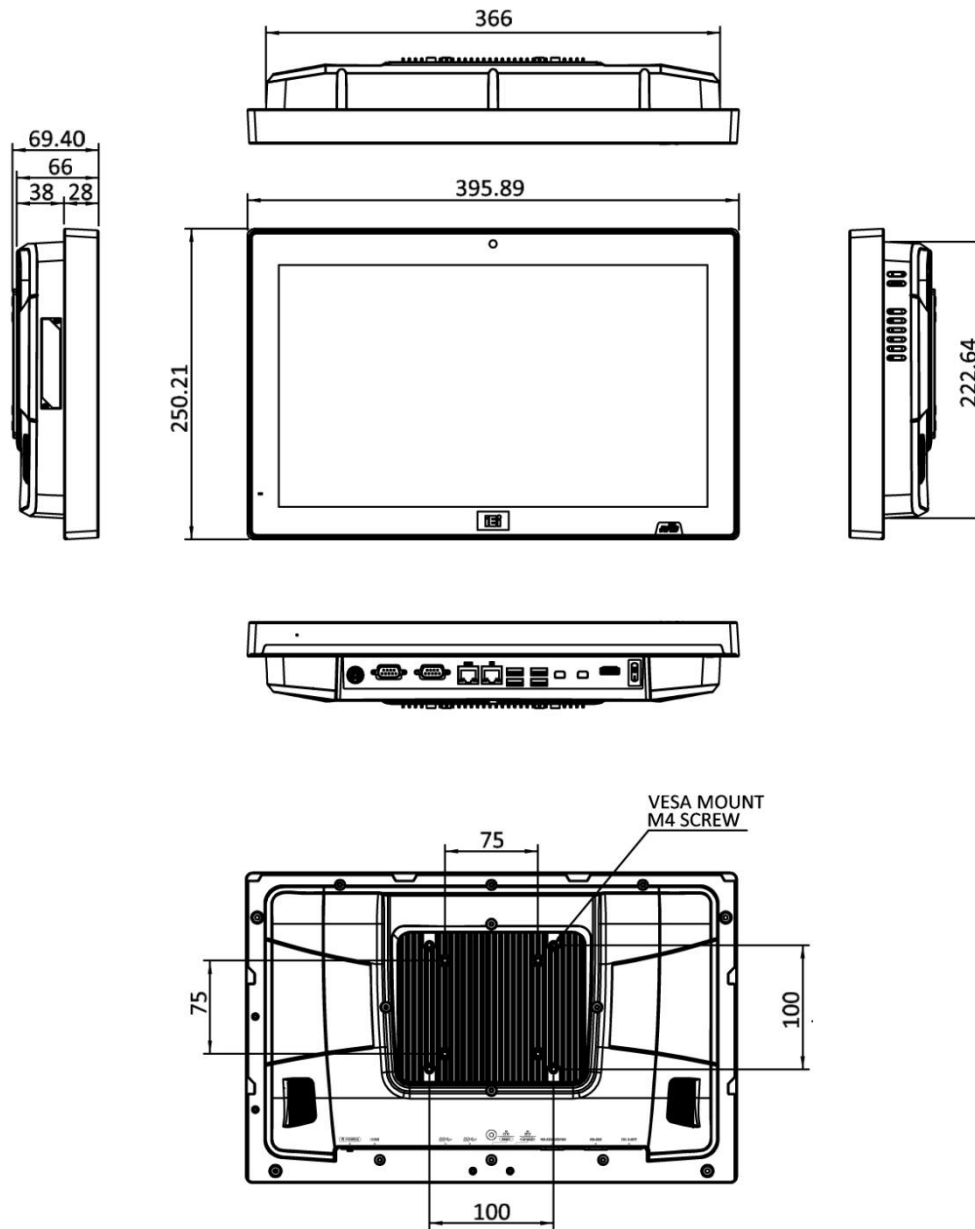


Figure 1-5: AFL3-W15C-ULT5 Dimensions (mm)



### 1.8.2 AFL3-W19C-ULT5 Dimensions

The AFL3-W19C-ULT5 dimensions are shown below.

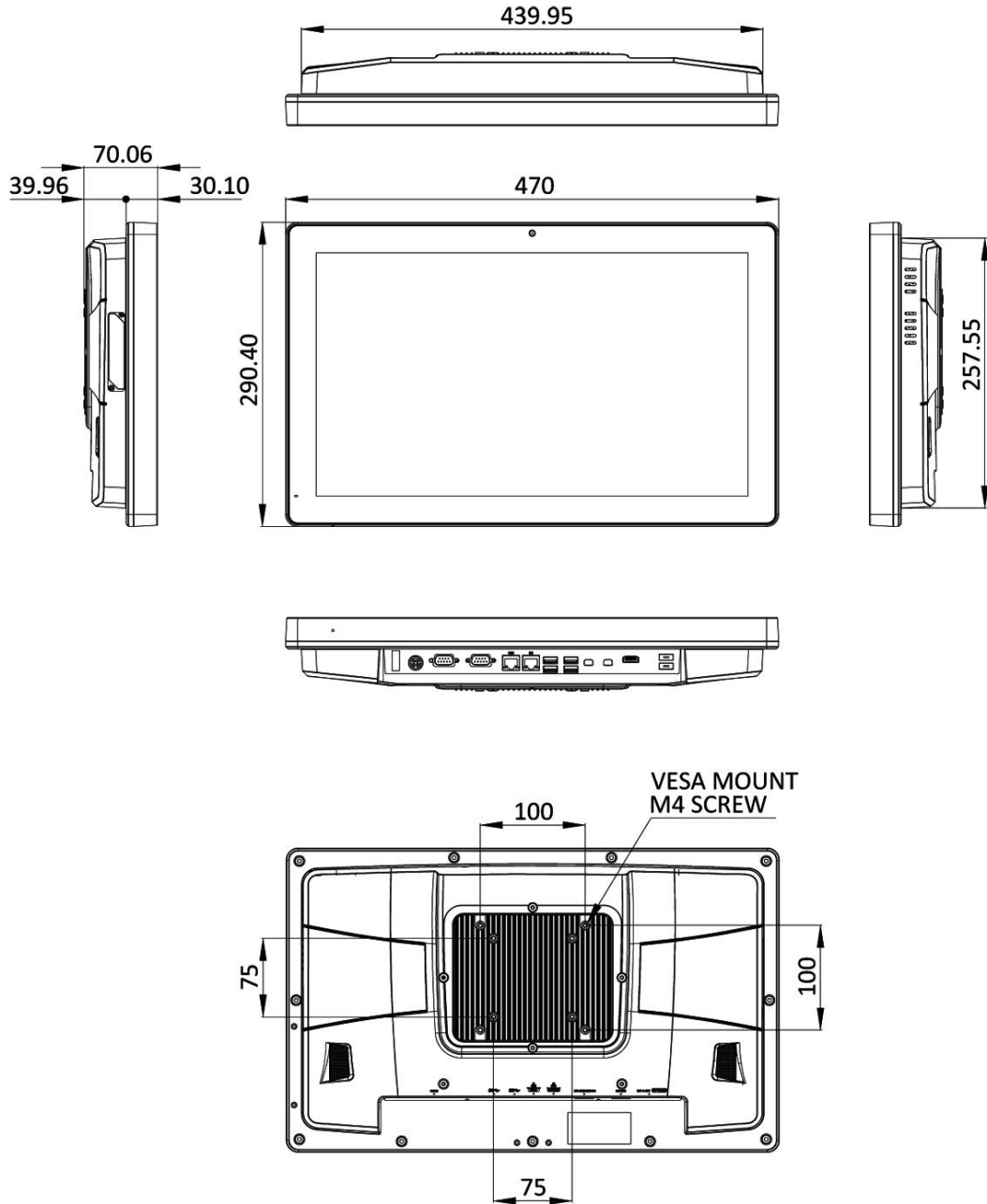
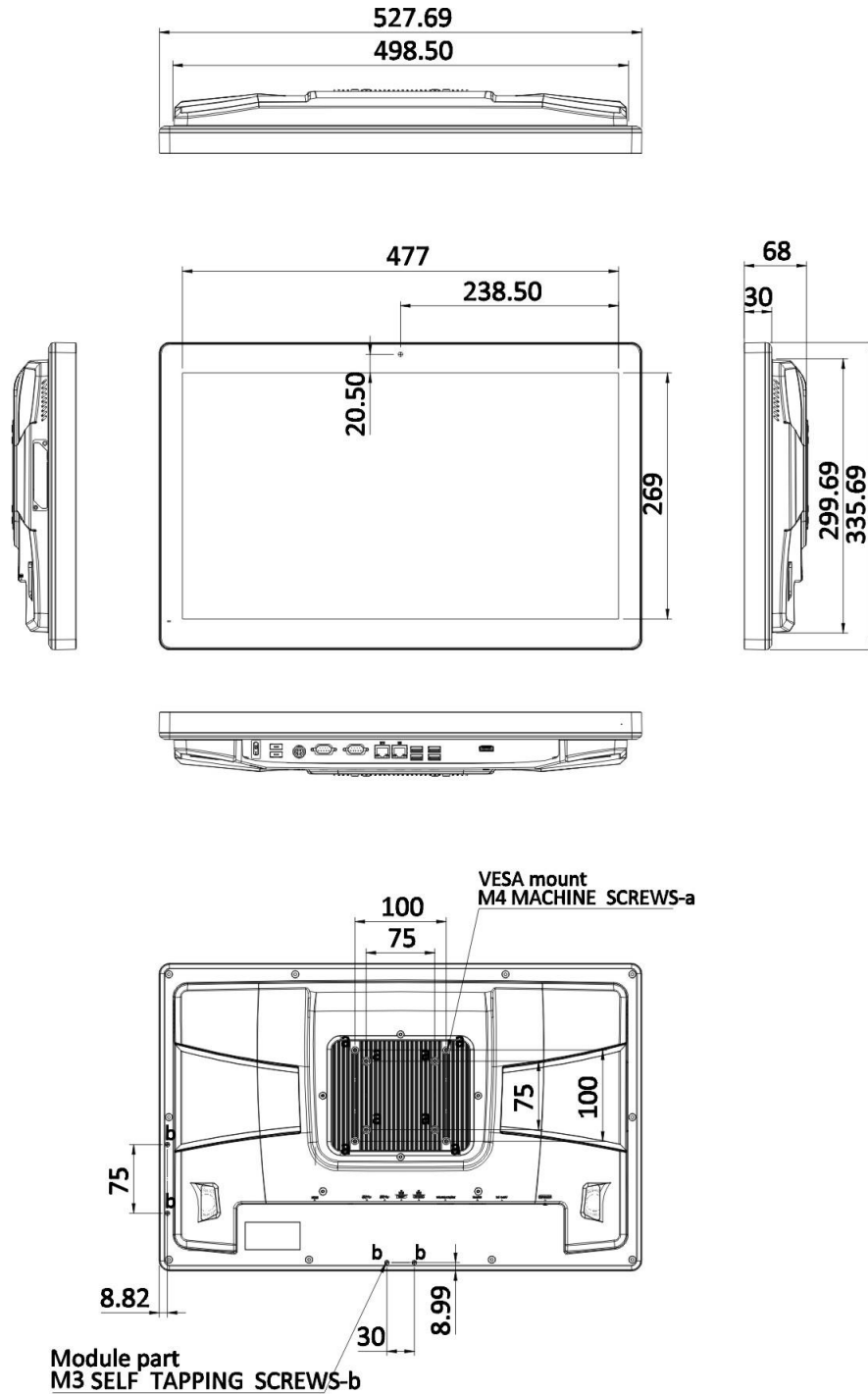


Figure 1-6: AFL3-W19C-ULT5 Dimensions (mm)

**AFL3-W15C/W19C/W22C-ULT5 Panel PC**

**1.8.3 AFL3-W22C-ULT5 Dimensions**

The AFL3-W22C-ULT5 dimensions are shown below.



**Figure 1-7: AFL3-W22C-ULT5 Dimensions (mm)**

Chapter

**2**

# Unpacking

---

## AFL3-W15C/W19C/W22C-ULT5 Panel PC

### 2.1 Unpacking

To unpack the flat bezel panel PC, follow the steps below:



#### **WARNING!**

The front side LCD screen has a protective plastic cover stuck to the screen. Only remove the plastic cover after the flat bezel panel PC has been properly installed. This ensures the screen is protected during the installation process.

---

**Step 1:** Carefully cut the tape sealing the box. Only cut deep enough to break the tape.

**Step 2:** Open the outside box.

**Step 3:** Carefully cut the tape sealing the box. Only cut deep enough to break the tape.

**Step 4:** Open the inside box.

**Step 5:** Lift the panel PC out of the boxes.

**Step 6:** Remove the peripheral parts box from the main box.

### 2.2 Packing List





#### **NOTE:**

If any of the components listed in the checklist below are missing, do not proceed with the installation. Contact the IEI reseller or vendor the AFL3-W15C/W19C/W22C-ULT5 was purchased from or contact an IEI sales representative directly by sending an email to [sales@ieiworld.com](mailto:sales@ieiworld.com).



---

The AFL3-W15C/W19C/W22C-ULT5 flat bezel panel PC is shipped with the following components:

Quantity	Item	Image
1	AFL3-W15C/W19C/W22C-ULT5 panel PC	
1	96 W power adapter	
1	Power cord	
4	Screws (M4*6) for VESA mounting	
4	Screws (M3*4) for HDD installation	

### 2.3 Optional Items

The following are optional components which may be separately purchased:

Item and Part Number	Image
IEEE802.3af/at/bt PoE PD module (P/N: GPOE-PD-BT01-R10)	
VESA 100 wall mount kit (P/N: AFLWK-19B)	



## AFL3-W15C/W19C/W22C-ULT5 Panel PC

Item and Part Number	Image
Panel mounting kit (P/N: AFL3PK-W15A-R10 for W15C) (P/N: AFL3PK-W19C-R10 for W19C & W22C)	
Arm (P/N: ARM-11-RS)	
Stand for VESA 75/VESA 100 (P/N: STAND-C19-R10)	
Barcode scanner (P/N: AFL3-2D-R11)	

If any of these items are missing or damaged, contact the distributor or sales representative immediately.

Chapter

**3**

# Installation

---

### 3.1 Anti-static Precautions

---

**WARNING:**

Failure to take ESD precautions during the maintenance of the AFL3-W15C/W19C/W22C-ULT5 may result in permanent damage to the AFL3-W15C/W19C/W22C-ULT5 and severe injury to the user.

---

Electrostatic discharge (ESD) can cause serious damage to electronic components, including the AFL3-W15C/W19C/W22C-ULT5. Dry climates are especially susceptible to ESD. It is therefore critical that whenever the AFL3-W15C/W19C/W22C-ULT5 is accessed internally, or any other electrical component is handled, the following anti-static precautions are strictly adhered to.

- **Wear an anti-static wristband:** Wearing a simple anti-static wristband can help to prevent ESD from damaging the board.
- **Self-grounding:** Before handling the board, touch any grounded conducting material. During the time the board is handled, frequently touch any conducting materials that are connected to the ground.
- **Use an anti-static pad:** When configuring the AFL3-W15C/W19C/W22C-ULT5, place it on an anti-static pad. This reduces the possibility of ESD damaging the AFL3-W15C/W19C/W22C-ULT5.
- **Only handle the edges of the PCB:** When handling the PCB, hold the PCB by the edges.

### 3.2 Installation Precautions

When installing the flat bezel panel PC, please follow the precautions listed below:

- **Power turned off:** When installing the flat bezel panel PC, make sure the power is off. Failing to turn off the power may cause severe injury to the body and/or damage to the system.
- **Certified Engineers:** Never open the equipment. For safety reasons, the equipment should be opened only by qualified skilled person.

- **Anti-static Discharge:** If a user open the rear panel of the flat bezel panel PC, to configure the jumpers or plug in added peripheral devices, ground themselves first and wear an anti-static wristband.

### 3.3 Installation and Configuration Steps

The following installation steps must be followed.

- Step 1:** Unpack the flat bezel panel PC.
- Step 2:** Install an M.2 SSD or a HDD.
- Step 3:** Configure the system.
- Step 4:** Connect peripheral devices to the flat bezel panel PC.
- Step 5:** Mount the flat bezel panel PC.

### 3.4 Removing the Back Covers

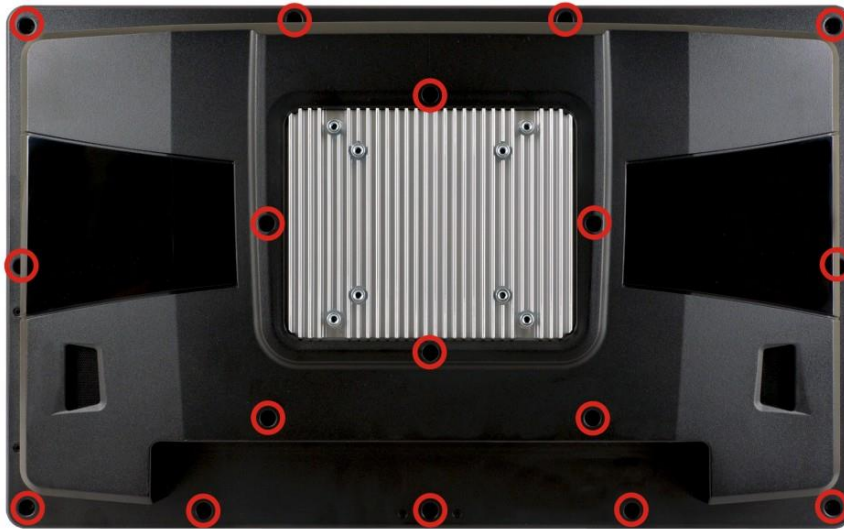
To access the AFL3-W15C/W19C/W22C-ULT5 internally, the plastic back cover and the internal metal cover must be removed. To remove the covers, please follow the steps below.

- Step 1:** Remove the retention screws from the back cover. Two types of screw are used for securing the plastic cover of the AFL3-W15C-ULT5. See **Figure 3-1** for detail. Be aware of this for reinstalling the plastic cover.

**AFL3-W15C/W19C/W22C-ULT5 Panel PC**

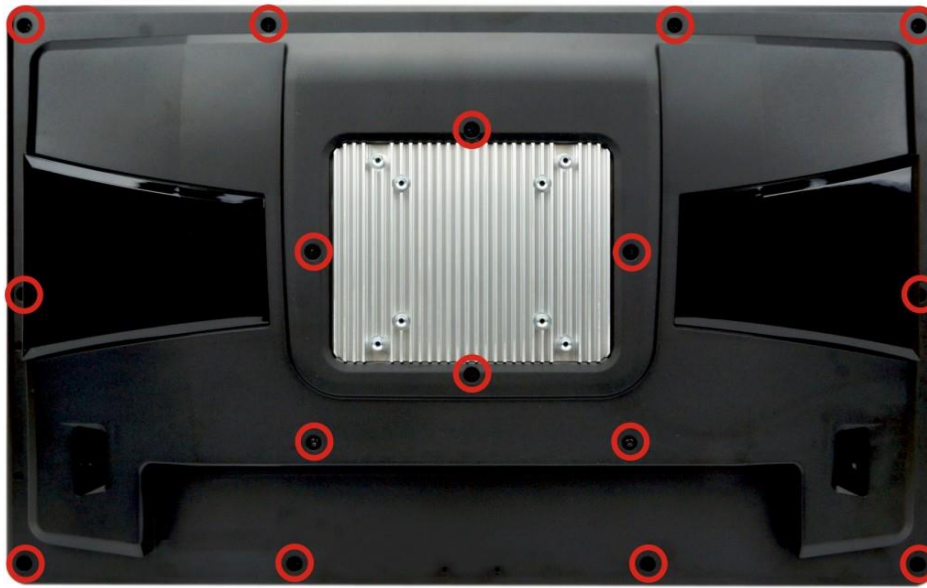


**Figure 3-1: AFL3-W15C-ULT5 Back Cover Retention Screws**



**Figure 3-2: AFL3-W19C-ULT5 Back Cover Retention Screws**





**Figure 3-3: AFL3-W22C-ULT5 Back Cover Retention Screws**

**Step 2:** Lift the plastic back cover off the AFL3-W15C/W19C/W22C-ULT5.

**Step 3:** Remove the retention screws from the internal metal cover. Two types of screw are used for securing the metal cover. See the following diagrams for detail. Be aware of this for reinstalling the metal cover.

For 15.6" panel PC: see **Figure 3-4**

For 18.5" panel PC: see **Figure 3-5**

For 21.5" panel PC: see **Figure 3-6**

AFL3-W15C/W19C/W22C-ULT5 Panel PC

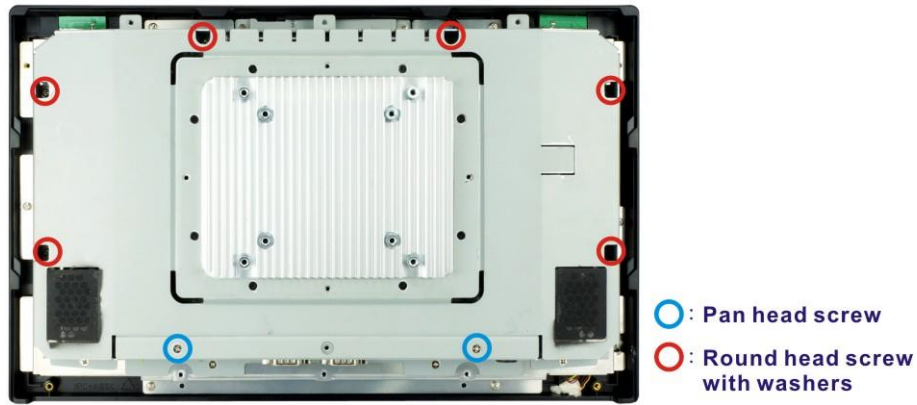


Figure 3-4: AFL3-W15C-ULT5 Metal Cover Retention Screws

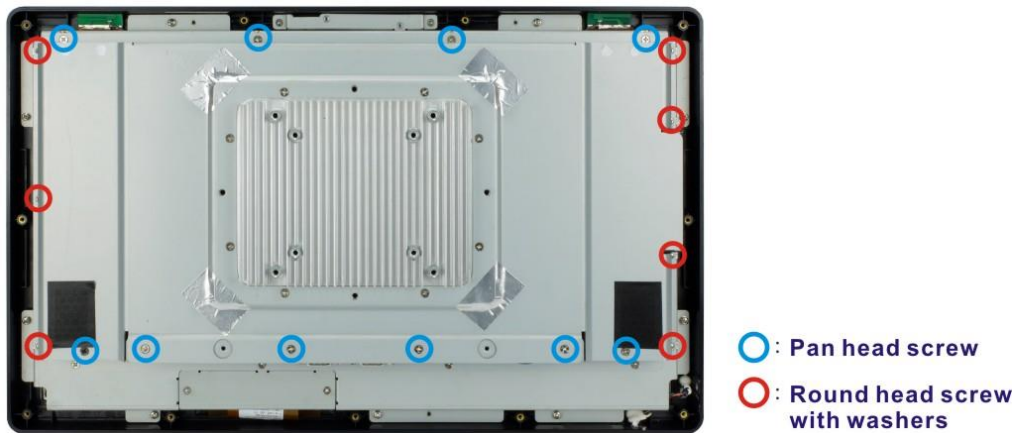


Figure 3-5: AFL3-W19C-ULT5 Metal Cover Retention Screws

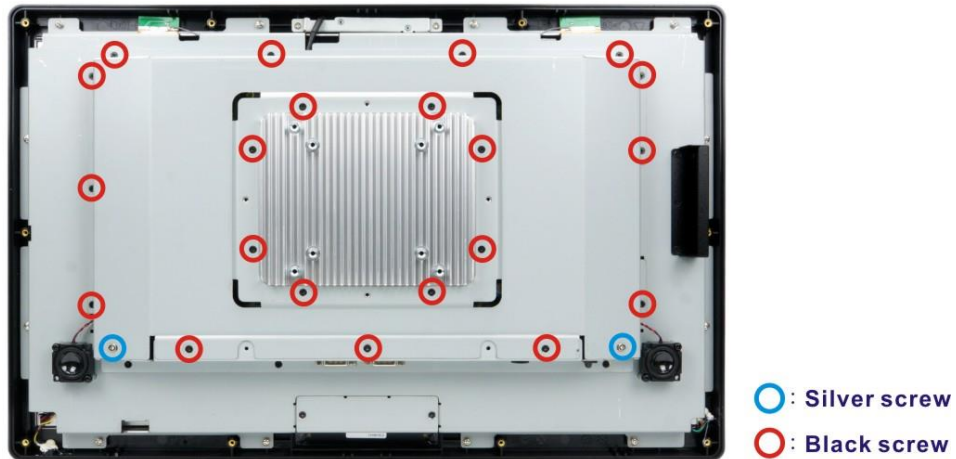


Figure 3-6: AFL3-W22C-ULT5 Metal Cover Retention Screws

**Step 4:** Lift the metal cover off the AFL3-W15C/W19C/W22C-ULT5. A thermal pad is attached under the center of the metal cover. To easily remove the cover, turn the cover in a clockwise direction first to detach the thermal pad before lifting the cover (**Figure 3-7**).



**Figure 3-7: Lift the Metal Cover**



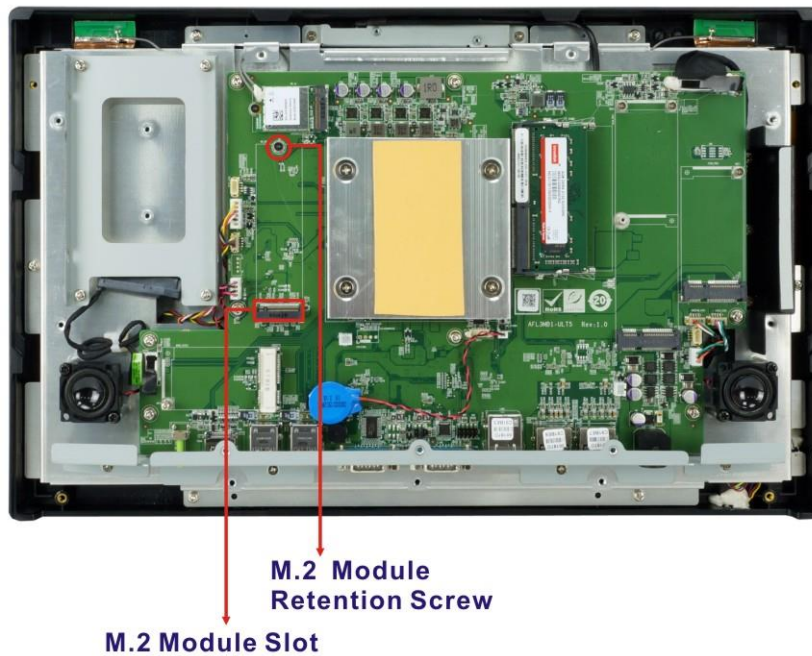
## AFL3-W15C/W19C/W22C-ULT5 Panel PC

### 3.5 M.2 Module Installation

The AFL3-W15C/W19C/W22C-ULT5 has an M.2 M-key slot for M.2 2280 module installation. To install an M.2 module into the AFL3-W15C/W19C/W22C-ULT5, please follow the steps below:

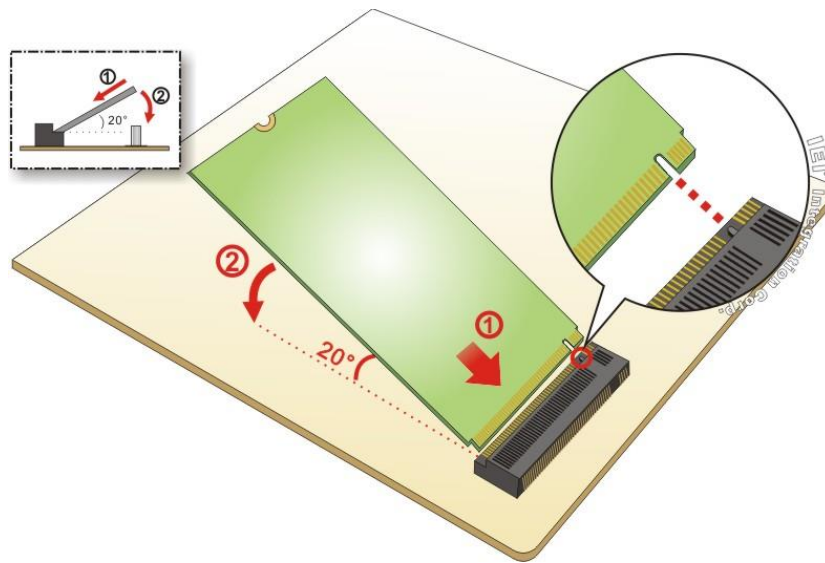
**Step 1:** Remove the plastic back cover and the internal metal cover. See **Section 3.4** above.

**Step 2:** Locate the M.2 slot. Remove the preinstalled retention screw on the motherboard as shown in **Figure 3-8**.



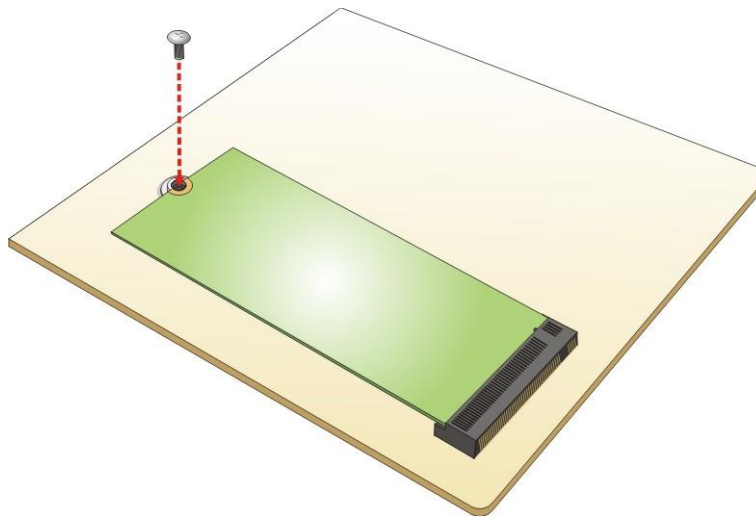
**Figure 3-8: M.2 Module Slot Location**

**Step 3:** Line up the notch on the card with the notch on the slot. Slide the PCIe Mini card into the socket at an angle of about 20° (**Figure 3-9**).



**Figure 3-9: Inserting the M.2 Module into the Slot at an Angle**

**Step 4:** Secure the M.2 module with the previously removed retention screw (Figure 3-10).



**Figure 3-10: Securing the M.2 Module**



## AFL3-W15C/W19C/W22C-ULT5 Panel PC

### 3.6 PCIe Mini Module Installation

To install a full-size PCIe Mini module into the AFL3-W15C/W19C/W22C-ULT5, please follow the steps below:

- Step 1:** Remove the plastic back cover and the internal metal cover. See **Section 3.4** above.
- Step 2:** Locate the PCIe Mini module slot. Remove the preinstalled retention screw on the screw pillar as shown in **Figure 3-11**.

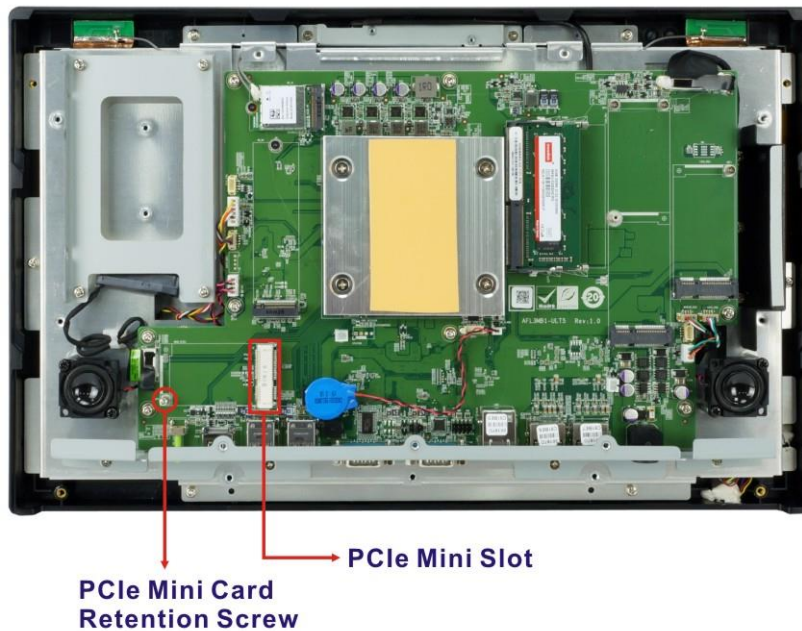
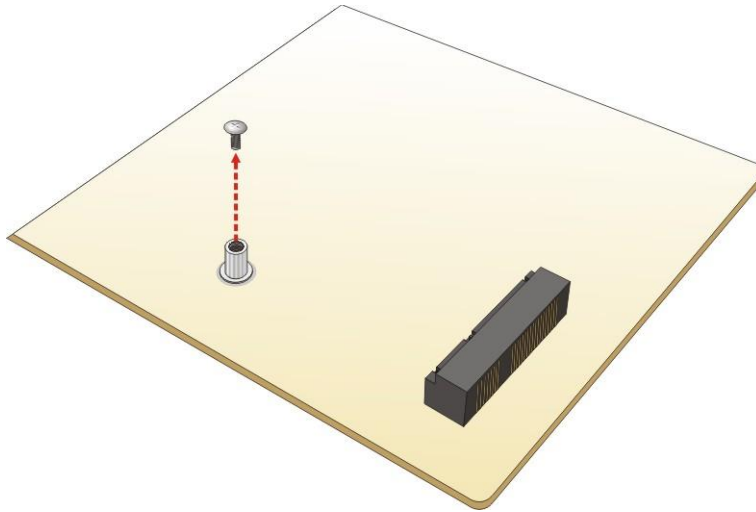


Figure 3-11: PCIe Mini Module Slot Location

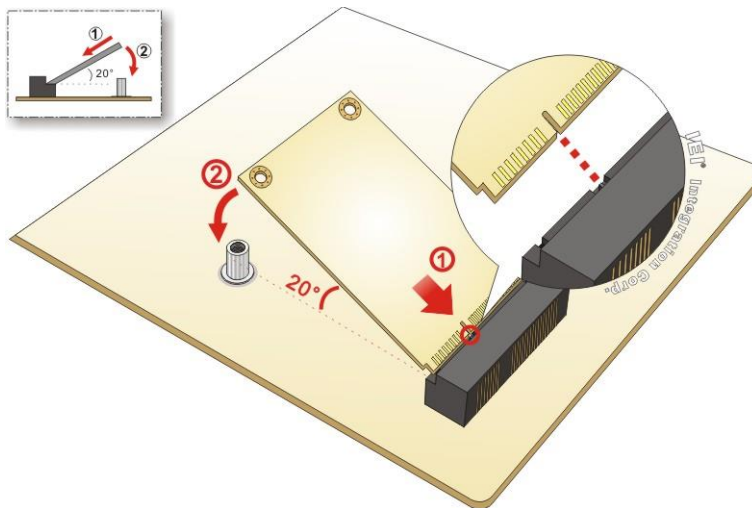
- Step 3:** Remove the retention screw as shown in Figure 3-12.



**Figure 3-12: Removing the Retention Screw**

**Step 4:** Line up the notch on the PCIe Mini module with the notch on the connector.

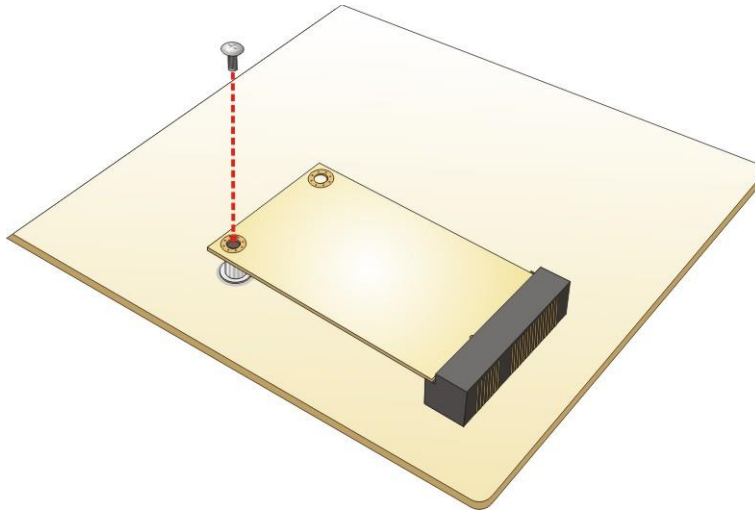
Slide the PCIe Mini card into the socket at an angle of about 20° (**Figure 3-13**).



**Figure 3-13: Installing a PCIe Mini Module**

**Step 5:** Secure the PCIe Mini module with the retention screw. Push the other end of the PCIe Mini module down and secure the module with the previously removed retention screw (**Figure 3-13**).

## AFL3-W15C/W19C/W22C-ULT5 Panel PC



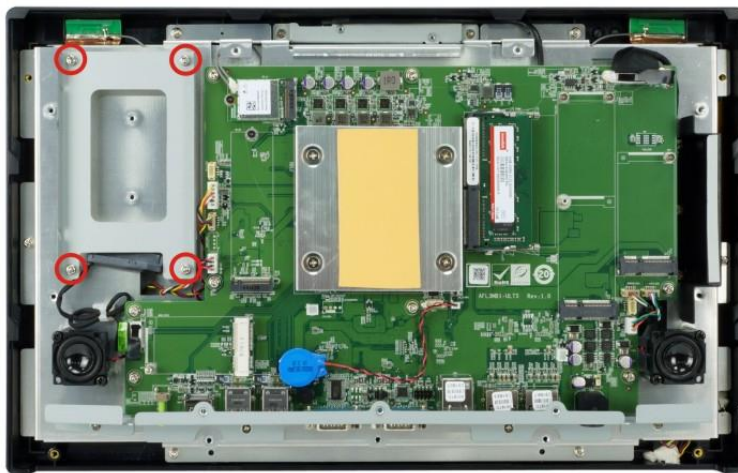
**Figure 3-14: Securing the PCIe Mini Module**

**Step 6:** Re-install the metal cover and the plastic back cover.

### 3.7 HDD Installation

To install the HDD into the system, please follow the steps below:

- Step 1:** Remove the plastic back cover and the internal metal cover. See **Section 3.4** above.
- Step 2:** Remove the four HDD bracket retention screws and lift the HDD bracket off the panel PC.



**Figure 3-15: HDD Bracket Retention Screws**

- Step 3:** Attach the HDD brackets to the HDD. To do this, align the four retention screw holes in the both sides of the HDD bracket with the retention screw holes on the sides of the HDD. Insert four retention screws into the HDD bracket (**Figure 3-16**).



## AFL3-W15C/W19C/W22C-ULT5 Panel PC



Figure 3-16: HDD Retention Screws

**Step 4:** Connect the SATA cable to the rear of HDD from the motherboard.

**Step 5:** Install the HDD into the AFL3-W15C/W19C/W22C-ULT5 by aligning the retention screw holes in the HDD brackets with the retention screw holes on the chassis. Insert the four retention screws.

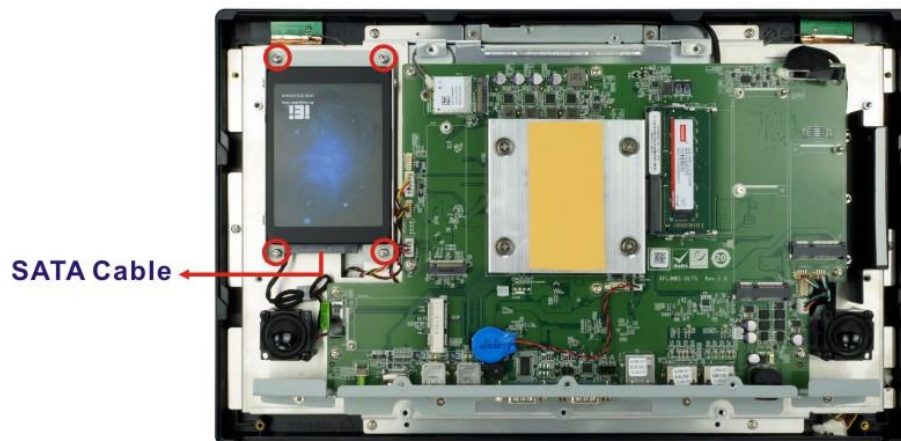


Figure 3-17: HDD Installation

**Step 6:** Replace the internal metal cover and the plastic back cover.



### 3.8 PoE PD Module Installation (Optional)

An IEI PoE module must be installed before start using the panel PC as a PoE powered device (PD). To install the optional PoE module, follow the steps below.

**Step 1:** Remove the plastic back cover and the internal metal cover. See **Section 3.4** above.

**Step 2:** Refer to the following diagram to locate the PoE module slot for installing the PoE module you purchased.



**Figure 3-18: PoE Module Slot Location**

**Step 3:** Line up the notch on the PoE module with the notch on the connector. Slide the PoE module into the socket at an angle of about 20°.

**Step 4:** Push the other end of the PoE module down and secure the module with the retention screw(s) came with the PoE module.

## AFL3-W15C/W19C/W22C-ULT5 Panel PC

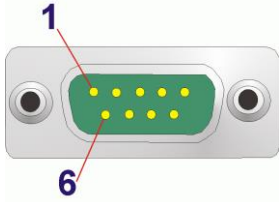
### 3.9 RS-232/422/485 Serial Port (COM1) Selection

The bottom panel of the AFL3-W15C/W19C/W22C-ULT5 has one D-sub 9 male connectors for RS-232/422/485 connection. The serial communication mode selection can be made through the BIOS options. Please refer to **Section 4.3.6.1.1** for detail information.

#### 3.9.1 COM1 Pinouts

The pinouts of COM1 external serial port are detailed below.

PIN NO.	RS-232	RS-422	RS-485
1	DCD	TXD422-	TXD485-
2	RXD	TXD422+	TXD485+
3	TXD	RXD422+	--
4	DTR	RXD422-	--
5	GND	--	--
6	DSR	--	--
7	RTS	--	--
8	CTS	--	--
9	RI	--	--



The diagram shows a 9-pin D-sub connector with a green PCB. Pin 1 is the top-left pin and pin 6 is the bottom-right pin. Red lines with numbers 1 and 6 point to these specific pins.

**Table 3-1: RS-232/422/485 Serial Port (COM1) Pinouts**

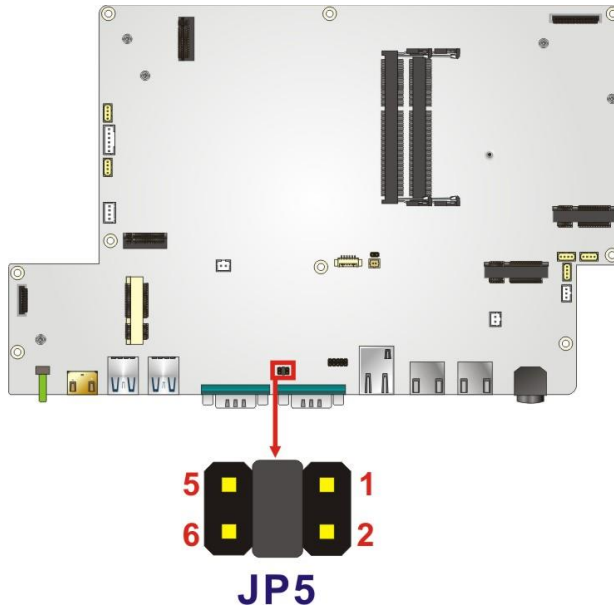
#### 3.9.2 COM1 Pin 9 Selection

Pin 9 on the COM1 DB-9 connector can be set as the ring (RI) signal, +5 V or +12 V. The jumper selection options are shown in **Table 3-2**.

JP5	Description
Short 1-2	COM1 RI Pin use +12 V
Short 3-4	COM1 RI Pin use RI (Default)
Short 5-6	COM1 RI Pin use +5 V

**Table 3-2: COM1 Pin 9 Setting Jumper Settings (JP5)**

The COM1 Pin 9 Setting jumper location is shown in **Figure 3-19** below.



**Figure 3-19: COM1 Pin 9 Setting Jumper Location**

### 3.10 Flash Descriptor Security Override

The Flash Descriptor Security Override jumper (ME\_FLASH1) allows to enable or disable the ME firmware update. Refer to **Figure 3-20** and **Table 3-3** for the jumper location and settings.

Setting	Description
Open	Disabled (default)
Short	Enabled

**Table 3-3: Flash Descriptor Security Override Jumper Settings**

## AFL3-W15C/W19C/W22C-ULT5 Panel PC

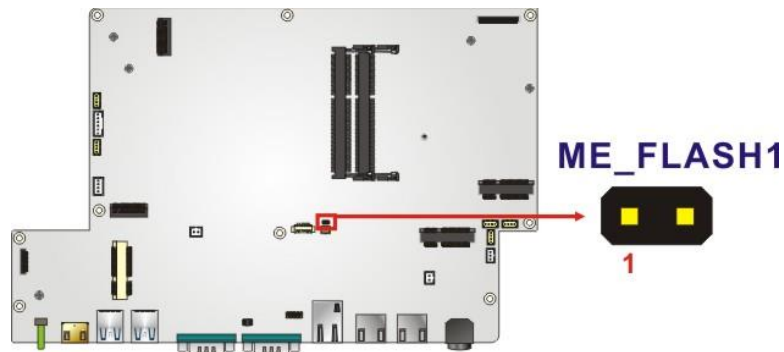


Figure 3-20: Flash Descriptor Security Override Jumper Location

To update the ME firmware, please follow the steps below.

- Step 1:** Before turning on the system power, short the Flash Descriptor Security Override jumper.
- Step 5:** Update the BIOS and ME firmware, and then turn off the system power.
- Step 2:** Remove the metal clip on the Flash Descriptor Security Override jumper.
- Step 3:** Restart the system. The system will reboot 2 ~ 3 times to complete the ME firmware update.

### 3.11 Clear CMOS

If the AFL3-W15C/W19C/W22C-ULT5 fails to boot due to improper BIOS settings, the clear CMOS jumper clears the CMOS data and resets the system BIOS information. To do this, push the clear CMOS button for three seconds, then restart the system. The clear CMOS button location is shown in **Figure 3-21**.

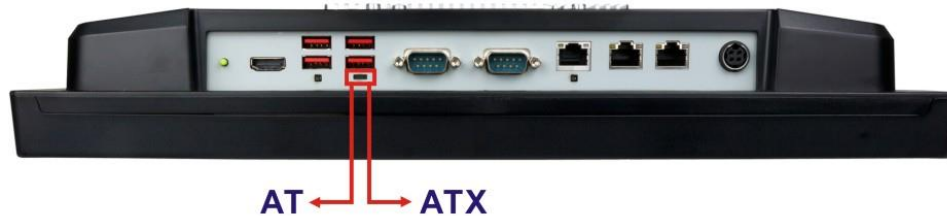


Figure 3-21: Clear CMOS Button Location



### 3.12 AT/ATX Mode Selection

AT or ATX power mode can be used on the AFL3-W15C/W19C/W22C-ULT5. The selection is made through an AT/ATX switch located on the bottom panel (**Figure 3-22**).



**Figure 3-22: AT/ATX Switch Location**

#### 3.12.1 AT Power Mode

With the AT mode selected, the power is controlled by a central power unit rather than a power switch. The AFL3-W15C/W19C/W22C-ULT5 panel PC turns on automatically when the power is connected. The AT mode benefits a production line to control multiple panel PCs from a central management center and other applications including:

- ATM
- Self-service kiosk
- Plant environment monitoring system
- Factory automation platform
- Manufacturing shop flow

#### 3.12.2 ATX Power Mode

With the ATX mode selected, the AFL3-W15C/W19C/W22C-ULT5 panel PC goes in a standby mode when it is turned off. The panel PC can be easily turned on via network or a power switch in standby mode. Remote power control is perfect for advertising applications since the broadcasting time for each panel PC can be set individually and controlled remotely. Other possible application includes

- Security surveillance
- Point-of-Sale (POS)
- Advertising terminal



## AFL3-W15C/W19C/W22C-ULT5 Panel PC

### 3.13 Mounting the System

The methods of mounting the AFL3-W15C/W19C/W22C-ULT5 are listed below.

- Wall mounting
- Panel mounting
- Rack mounting
- Arm mounting
- Stand mounting

The mounting methods are described below.

#### 3.13.1 Wall Mounting

To mount the flat bezel panel PC onto the wall, please follow the steps below.

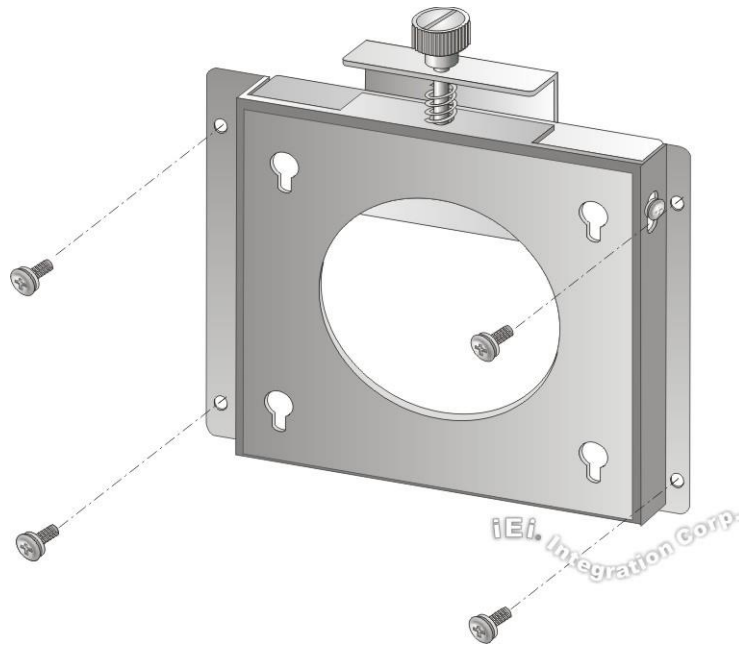
**Step 1:** Select the location on the wall for the wall-mounting bracket.

**Step 2:** Carefully mark the locations of the four screw holes in the bracket on the wall.

**Step 3:** Drill four pilot holes at the marked locations on the wall for the bracket retention screws.

**Step 4:** Align the wall-mounting bracket screw holes with the pilot holes.

**Step 5:** Secure the mounting-bracket to the wall by inserting the retention screws into the four pilot holes and tightening them (**Figure 3-23**).



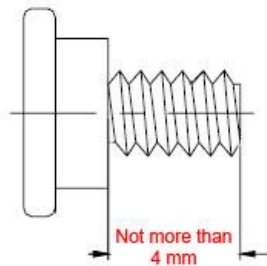
**Figure 3-23: Wall-mounting Bracket**

**Step 6:** Insert the four monitor mounting screws provided in the wall mount kit into the four screw holes on the rear panel of the flat bezel panel PC and tighten until the screw shank is secured against the rear panel (**Figure 3-24**).



**WARNING:**

Please use the M4 screws provided in the wall mount kit for the rear panel. If the screw is missing, the thread depth of the replacement screw should be not more than 4 mm.



**AFL3-W15C/W19C/W22C-ULT5 Panel PC**

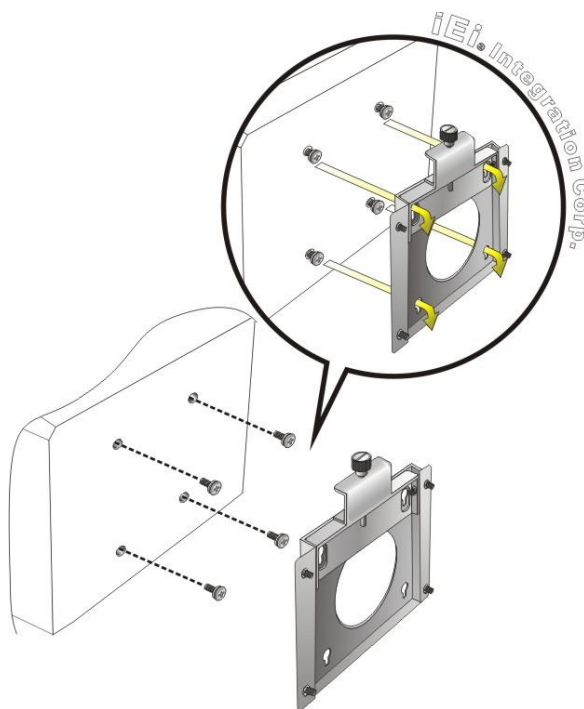
**Step 7:** Align the mounting screws on the monitor rear panel with the mounting holes on the bracket.

**Step 8:** Carefully insert the screws through the holes and gently pull the monitor downwards until the monitor rests securely in the slotted holes (**Figure 3-24**). Ensure that all four of the mounting screws fit snugly into their respective slotted holes.

**NOTE:**

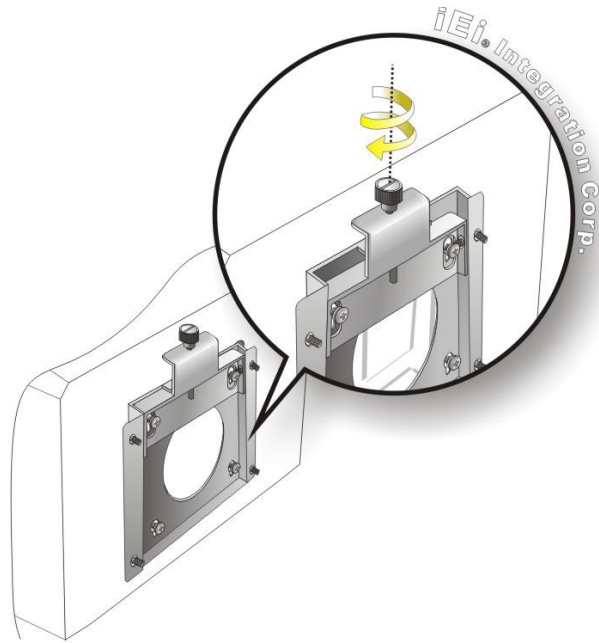
In the diagram below the bracket is already installed on the wall.

---



**Figure 3-24: Chassis Support Screws**

**Step 9:** Secure the panel PC by fastening the retention screw of the wall-mounting bracket (**Figure 3-25**).

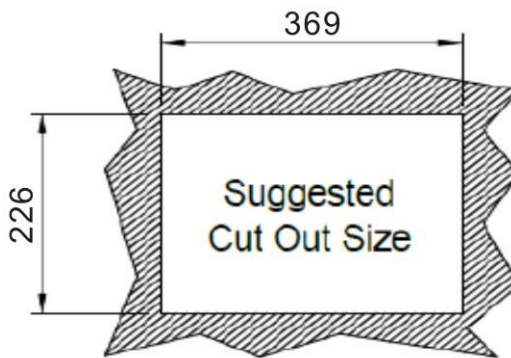


**Figure 3-25: Secure the Panel PC**

### 3.13.2 Panel Mounting

To mount the AFL3-W15C/W19C/W22C-ULT5 flat bezel panel PC into a panel, please follow the steps below.

- Step 1:** Select the position on the panel to mount the panel PC.
- Step 2:** Cut out a section corresponding to the size shown below. The size must be smaller than the outer edge.



**Figure 3-26: AFL3-W15C-ULT5 Cutout Dimensions**

AFL3-W15C/W19C/W22C-ULT5 Panel PC

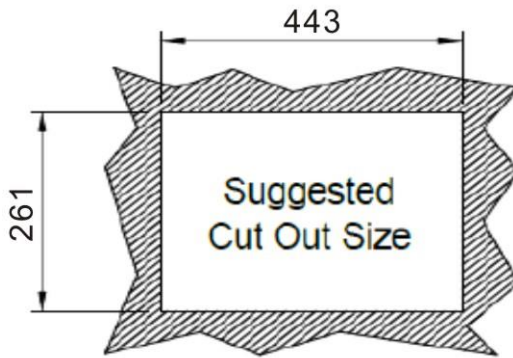


Figure 3-27: AFL3-W19C-ULT5 Cutout Dimensions

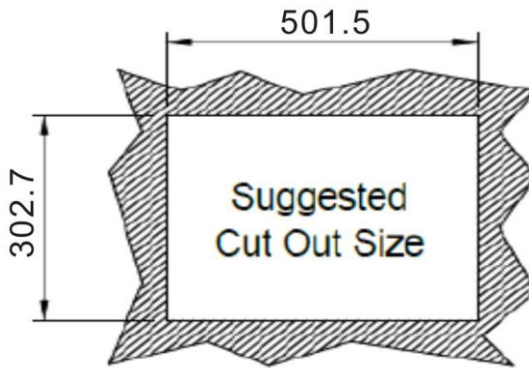





Figure 3-28: AFL3-W22C-ULT5 Cutout Dimensions

**Step 3:** Slide the panel PC through the hole until the frame is flush against the panel.

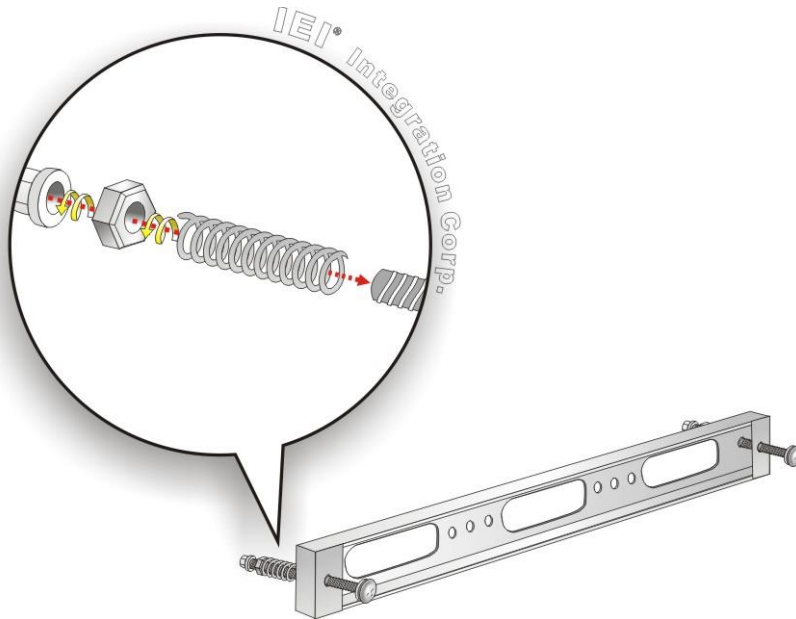
**Step 4:** Insert a M5\*50 screw into the screw hole on the side of the panel mounting bracket. Then, install the following components onto the screw in sequence.

See **Figure 3-29**.

Sequence	Item	Photo	Instruction
1	Spring		Install a spring onto the screw.
2	Nut		Tighten a nut until the spring is compressed enough for plastic cap.
3	Plastic cap		Tighten a plastic cap onto the end of screw thread.



**Step 5:** Repeat **Step 4** to install the other three screws into the sides of the two panel mounting brackets.

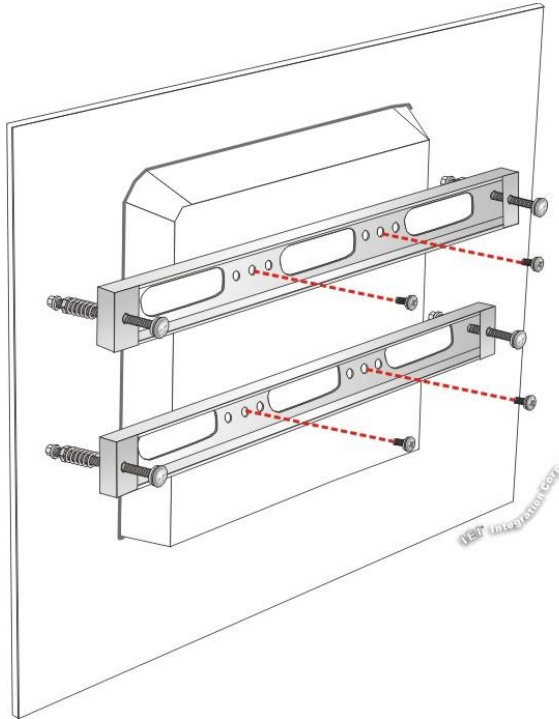


**Figure 3-29: Panel Mounting Kit Installation**

**Step 6:** Align the panel mounting bracket screw holes with the VESA mounting holes on the rear of the panel PC.

**Step 7:** Secure the two panel mounting brackets to the rear of the panel PC by inserting the four retention screws into the VESA mounting holes and tightening them (**Figure 3-30**).

**AFL3-W15C/W19C/W22C-ULT5 Panel PC**



**Figure 3-30: Securing Panel Mounting Brackets**



**NOTE:**

The panel mounting kit described in this section is an optional item. To purchase it, please contact an IEI sales representative.

### 3.13.3 Cabinet and Rack Installation

The AFL3-W15C/W19C/W22C-ULT5 flat bezel panel PC can be installed into a cabinet or rack. The installation procedures are similar to the panel mounting installation. To do this, please follow the steps below:






**NOTE:**

When purchasing the cabinet/rack installation bracket, make sure it is compatible with both the AFL3-W15C/W19C/W22C-ULT5 flat bezel panel PC and the rack/cabinet into which the AFL3-W15C/W19C/W22C-ULT5 is installed.

**Step 1:** Slide the rear chassis of the AFL3-W15C/W19C/W22C-ULT5 panel PC through the rack/cabinet bracket until the frame is flush against the front of the bracket.

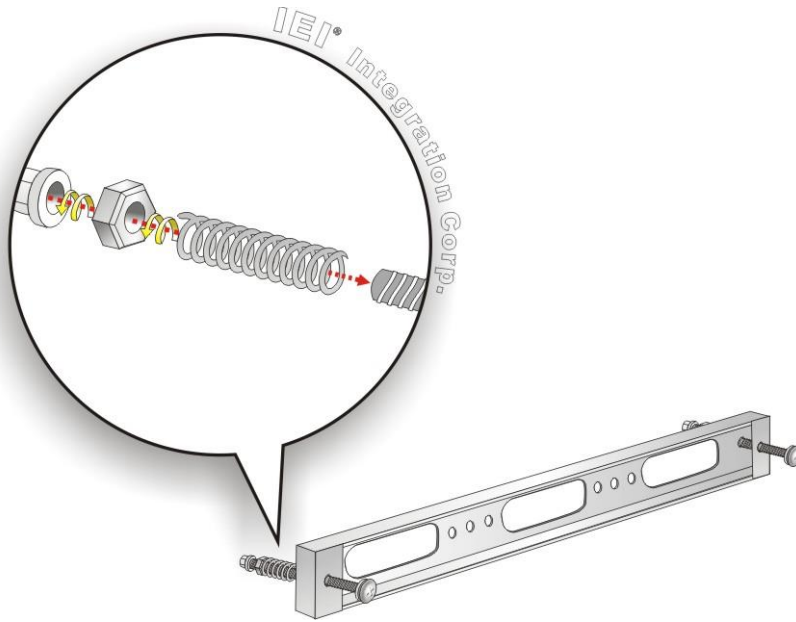
**Step 2:** Insert a M5\*50 screw into the screw hole on the side of the rack mounting bracket. Then, install the following components onto the screw in sequence.

See **Figure 3-29**.

Sequence	Item	Photo	Instruction
1	Spring		Install a spring onto the screw.
2	Nut		Tighten a nut until the spring is compressed enough for plastic cap.
3	Plastic cap		Tighten a plastic cap onto the end of screw thread.

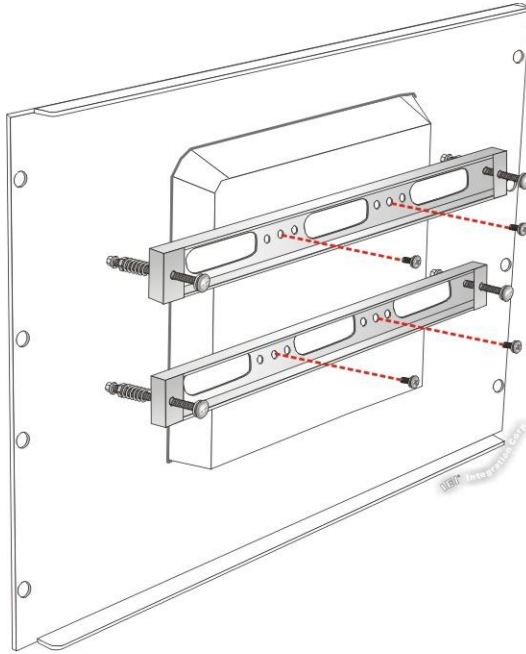
**Step 3:** Repeat **Step 4** to install the other three screws into the sides of the two rack mounting brackets.

## AFL3-W15C/W19C/W22C-ULT5 Panel PC



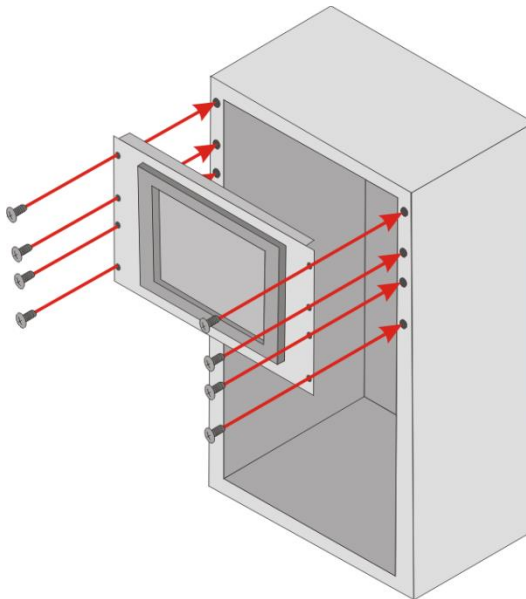
**Figure 3-31: Rack Mounting Kit Installation**

- Step 4:** Align the rack mounting bracket screw holes with the VESA mounting holes on the rear of the panel PC.
- Step 5:** Secure the two rack mounting brackets to the rear of the panel PC by inserting the four retention screws into the VESA mounting holes and tightening them (Figure 3-32).



**Figure 3-32: Securing Rack Mounting Brackets**

**Step 6:** Slide the panel PC with the attached rack/cabinet bracket into a rack or cabinet (Figure 3-33).



**Figure 3-33: Install into a Rack/Cabinet**



## AFL3-W15C/W19C/W22C-ULT5 Panel PC

**Step 7:** Once the panel PC with the attached rack/cabinet bracket has been properly inserted into the rack or cabinet, secure the front of the rack/cabinet bracket to the front of the rack or cabinet (**Figure 3-33**).



### NOTE:

The rack mounting kit described in this section is an optional item. To purchase it, please contact an IEI sales representative.

---

### 3.13.4 Arm Mounting

The AFL3-W15C/W19C/W22C-ULT5 is VESA (Video Electronics Standards Association) compliant and can be mounted on an arm with a 75 mm or a 100 mm interface pad. To mount the AFL3-W15C/W19C/W22C-ULT5 on an arm, please follow the steps below.

**Step 1:** The arm is a separately purchased item. Please correctly mount the arm onto the surface it uses as a base. To do this, refer to the installation documentation that came with the mounting arm.



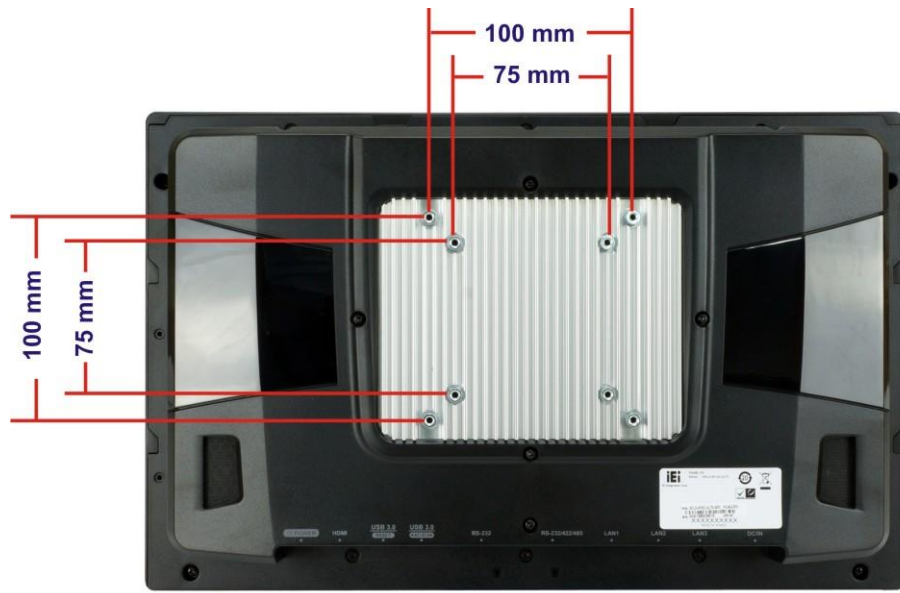
### NOTE:

When purchasing the arm please ensure that it is VESA compliant and that the arm has a 75 mm or a 100 mm interface pad. If the mounting arm is not VESA compliant it cannot be used to support the AFL3-W15C/W19C/W22C-ULT5 flat bezel panel PC.

---

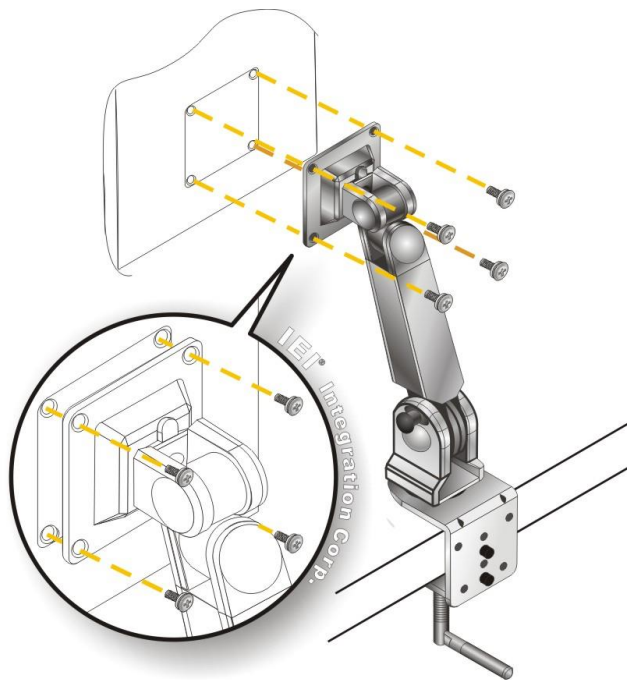
**Step 2:** Once the mounting arm has been firmly attached to the surface, lift the flat bezel panel PC onto the interface pad of the mounting arm.

**Step 3:** Align the retention screw holes on the mounting arm interface with those in the flat bezel panel PC (**Figure 3-34**).



**Figure 3-34: Arm Mounting Retention Screw Holes**

**Step 4:** Secure the AFL3-W15C/W19C/W22C-ULT5 to the interface pad by inserting four retention screws through the mounting arm interface pad and into the AFL3-W15C/W19C/W22C-ULT5.



**Figure 3-35: Arm Mounting**

## AFL3-W15C/W19C/W22C-ULT5 Panel PC

### 3.13.5 Stand Mounting

To mount the AFL3-W15C/W19C/W22C-ULT5 using the stand mounting kit, please follow the steps below.

- Step 1:** Locate the screw holes on the rear of the AFL3-W15C/W19C/W22C-ULT5. This is where the bracket will be attached.
- Step 2:** Align the bracket with the screw holes.
- Step 3:** To secure the bracket to the AFL3-W15C/W19C/W22C-ULT5 insert the retention screws into the screw holes and tighten them.

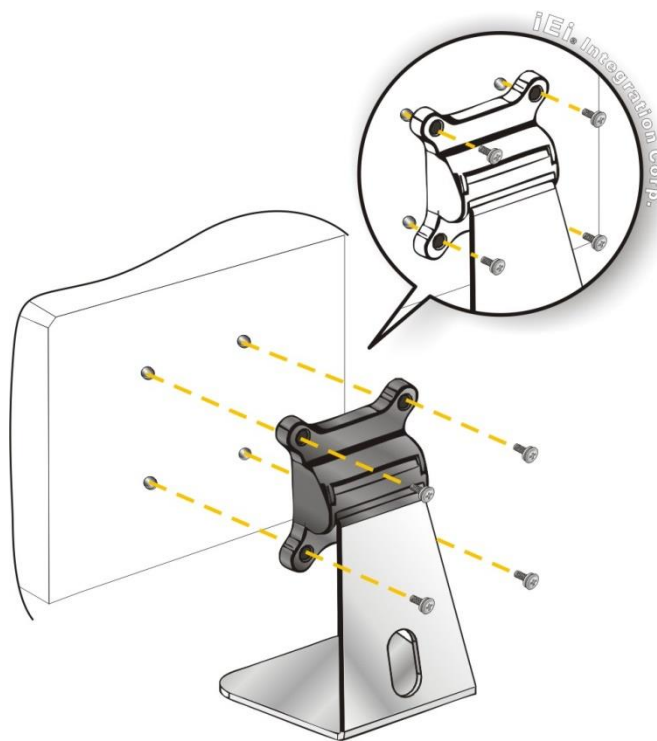


Figure 3-36: Stand Mounting (Stand-A/Bxx)

### 3.14 Powering On the System

To power on the system, follow the steps below:

- Step 1:** Connect the power cord to the power adapter. Connect the other end of the power cord to a power source. **Ensure to connect the power cord to a socket-outlet with earthing connection.**
- Step 2:** Connect the power adapter to the power connector of the AFL3-W15C/W19C/W22C-ULT5.
- Step 3:** Locate the power button on the I/O panel.
- Step 4:** Hold down the power button until the power LED on the front panel turns on in green.

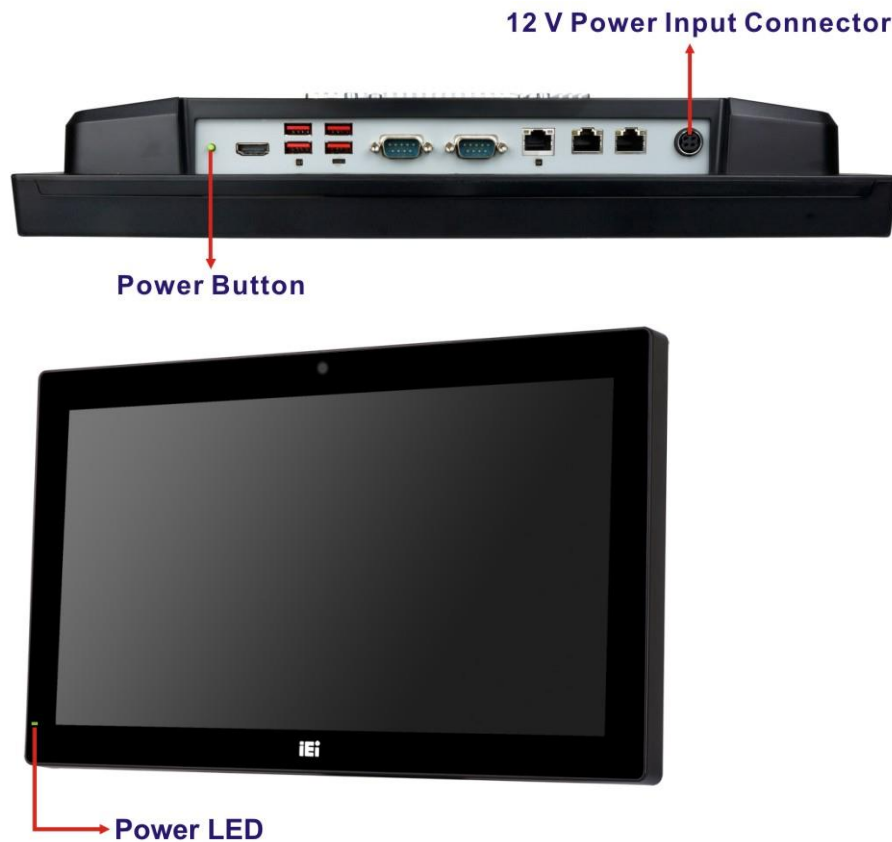


Figure 3-37: Powering On the System



## AFL3-W15C/W19C/W22C-ULT5 Panel PC

### 3.15 Reset the System

The reset button enables user to reboot the system when the system is on. The reset button location is shown in **Figure 3-38**. Press the reset button to reboot the system.



Figure 3-38: Reset Button Location

### 3.16 Software Installation

All the drivers for the AFL3-W15C/W19C/W22C-ULT5 are available on IEI Resource Download Center (<https://download.ieiworld.com>). Type the model name and press **Enter** to find all the relevant software, utilities, and documentation.

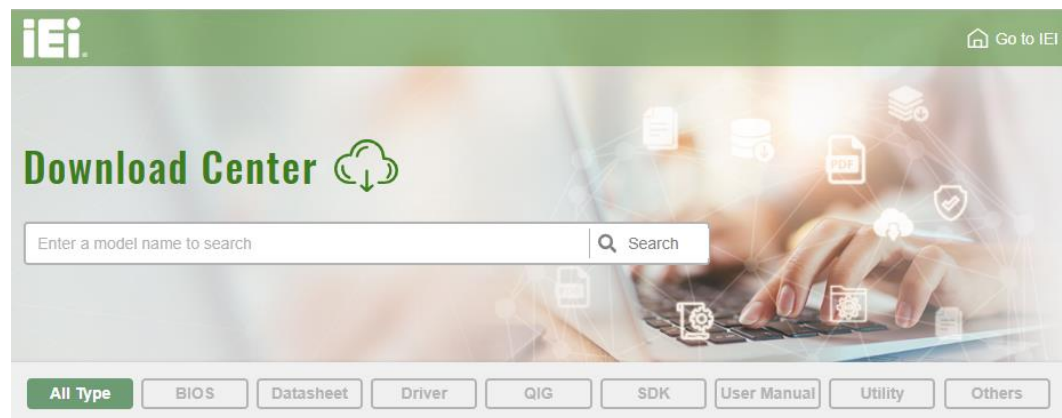


Figure 3-39: IEI Resource Download Center





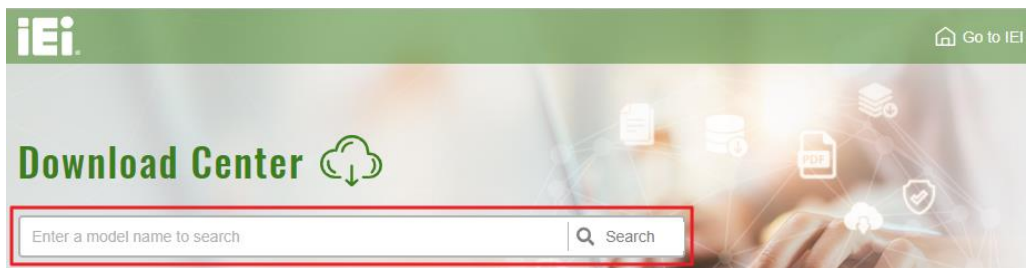
**NOTE:**

The panel PC with projected capacitive type touchscreen and Windows 7 (or later) OS does not require touch driver installation. This is because there is a HID touch digitizer built-in driver in Windows 7 or later.

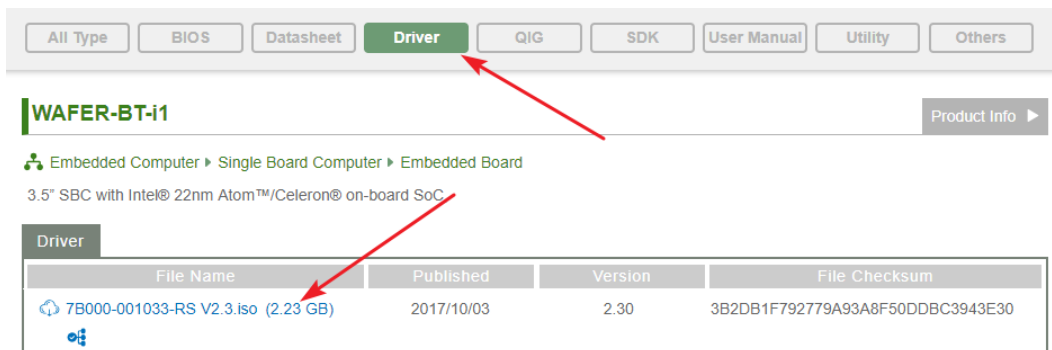
**3.16.1 Driver Download**

To download drivers from IEI Resource Download Center, follow the steps below.

**Step 1:** Go to <https://download.ieiworld.com>. Type the model name and press Enter.

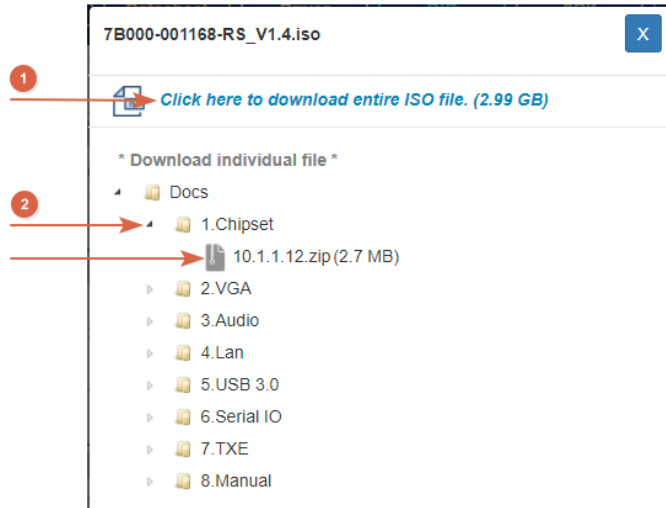


**Step 2:** All product-related software, utilities, and documentation will be listed. You can choose **Driver** to filter the result.



## AFL3-W15C/W19C/W22C-ULT5 Panel PC

**Step 3:** Click the driver file name on the page and you will be prompted with the following window. You can download the entire ISO file (❶), or click the small arrow to find an individual driver and click the file name to download (❷).

**NOTE:**

To install software from the downloaded ISO image file in Windows 8 (or later), double-click the ISO file to mount it as a virtual drive to view its content. On Windows 7 system, an additional tool (such as Virtual CD-ROM Control Panel from Microsoft) is needed to mount the file.

Chapter

**4**

# BIOS Setup

---

## 4.1 Introduction

The BIOS is programmed onto the BIOS chip. The BIOS setup program allows changes to certain system settings. This chapter outlines the options that can be changed.



### NOTE:

Some of the BIOS options may vary throughout the life cycle of the product and are subject to change without prior notice.

### 4.1.1 Starting Setup

The UEFI BIOS is activated when the computer is turned on. The setup program can be activated in one of two ways.

1. Press the **DELETE** or **F2** key as soon as the system is turned on or
2. Press the **DELETE** or **F2** key when the “**Press Del to enter SETUP**” message appears on the screen.

If the message disappears before the **DELETE** or **F2** key is pressed, restart the computer and try again.

### 4.1.2 Using Setup

Use the arrow keys to highlight items, press **ENTER** to select, use the PageUp and PageDown keys to change entries, press **F1** for help and press **ESC** to quit. Navigation keys are shown in.

Key	Function
Up arrow	Move to previous item
Down arrow	Move to next item
Left arrow	Move to the item on the left hand side
Right arrow	Move to the item on the right hand side
+	Increase the numeric value or make changes

Key	Function
-	Decrease the numeric value or make changes
F1 key	General help, only for Status Page Setup Menu and Option Page Setup Menu
F2 key	Load previous values.
F3 key	Load optimized defaults
F4 key	Save changes and Exit BIOS
Esc key	Main Menu – Quit and not save changes into CMOS Status Page Setup Menu and Option Page Setup Menu -- Exit current page and return to Main Menu

#### 4.1.3 Getting Help

When **F1** is pressed a small help window describing the appropriate keys to use and the possible selections for the highlighted item appears. To exit the Help Window press **Esc** or the **F1** key again.

#### 4.1.4 Unable to Reboot after Configuration Changes

If the computer cannot boot after changes to the system configuration is made, CMOS defaults. Use the jumper described in **Section 3.11**.

#### 4.1.5 BIOS Menu Bar

The **menu bar** on top of the BIOS screen has the following main items:

- Main – Changes the basic system configuration.
- Advanced – Changes the advanced system settings.
- Chipset – Changes the chipset settings.
- Security – Sets User and Supervisor Passwords.
- Boot – Changes the system boot configuration.
- Save & Exit – Selects exit options and loads default settings

The following sections completely describe the configuration options found in the menu items at the top of the BIOS screen and listed above.



## AFL3-W15C/W19C/W22C-ULT5 Panel PC

### 4.2 Main

The **Main** BIOS menu (**BIOS Menu 1**) appears when the **BIOS Setup** program is entered.

```

Aptio Setup Utility - Copyright (C) 2019 American Megatrends, Inc.
  Main  Advanced  Chipset  Security  Boot  Save & Exit
BIOS Information
BIOS Vendor                American Megatrends
Core Version                5.13
Compliancy                 UEFI 2.7; PI 1.6
Project Version            Z621AR11.ROM
Build Date and Time        10/25/2019 17:05:06

iWDD Vendor                iEi
iWDD Version                Z261ER10.bin

Processor Information
Name                       WhiskeyLake ULT
Type                       Intel(R) Core(TM)
                           i5-8365UE CPU @ 1.60GHz
Speed                      1800 MHz
ID                          0x806EC
Stepping                   V0
Number of Processors       4Core(s) / 8Thread(s)
Microcode Revision         B8
GT Info                     GT2 (0x3EA0)

IGFX VBIOS Version         1017
Memory RC Version          0.7.1.95
Total Memory                4096 MB
Memory Frequency           2133 MHz

PCH Information
Name                       CNL PCH-LP
PCH SKU                     (U) Premium SKU
Stepping                   D0

ME FW Version               12.0.37.1429
ME Firmware SKU            Consumer SKU

Access Level                Administrator

System Date                 [Fri 01/01/2010]
System Time                 [00:18:35]

Version 2.20.1271. Copyright (C) 2019 American Megatrends, Inc.
  
```

#### BIOS Menu 1: Main

The System Overview field also has two user configurable fields:

➔ **System Date [xx/xx/xx]**

Use the **System Date** option to set the system date. Manually enter the day, month and year.

➔ **System Time [xx:xx:xx]**

Use the **System Time** option to set the system time. Manually enter the hours, minutes and seconds.

### 4.3 Advanced

Use the **Advanced** menu (**BIOS Menu 2**) to configure the CPU and peripheral devices through the following sub-menus:



**WARNING!**

Setting the wrong values in the sections below may cause the system to malfunction. Make sure that the settings made are compatible with the hardware.

```

Aptio Setup Utility - Copyright (C) 2019 American Megatrends, Inc.
Main  Advanced  Chipset  Security  Boot  Save & Exit

> CPU Configuration          CPU Configuration
> PCH-FW Configuration      Parameters.
> ACPI Settings
> RTC Wake Settings
> iWDD H/W Monitor
> F81866 Super IO Configuration
> Serial Port Console Redirection
> USB Configuration
> NVMe Configuration
> iEi Feature

-----
<=>: Select Screen
↑↓: Select Item
Enter>Select
F1  General Help
F2  Previous Values
F3  Optimized Defaults
F4  Save
ESC Exit

Version 2.20.1271. Copyright (C) 2019 American Megatrends, Inc.
    
```

**BIOS Menu 2: Advanced**

## AFL3-W15C/W19C/W22C-ULT5 Panel PC

### 4.3.1 CPU Configuration

Use the **CPU Configuration** menu (**BIOS Menu 3**) to view detailed CPU specifications and configure the CPU.

```

Aptio Setup Utility - Copyright (C) 2019 American Megatrends, Inc.
  Advanced
CPU Configuration
Type                Intel(R) Core(TM)
                   i5-8365UE CPU@
                   1.60GHz
ID                  0x806EC
Speed               1800 MHz
L1 Data Cache      32 KB x 4
L1 Instruction Cache 32 KB x 4
L2 Cache           256 KB x 4
L3 Cache           6 MB
L4 Cache           N/A
VMX                 Supported
SMX/TXT             Supported

Intel (VMX) Virtualization Technology [Disabled]
Active Processor Cores [All]
Hyper-Threading      [Enabled]
Intel(R) SpeedStep(tm) [Enabled]
C states              [Disabled]
Intel Trusted Execution Technology [Disabled]

When enabled, a VMM can utilize the additional hardware capabilities provided by Vanderpool Technology.

-----
<->: Select Screen
↑ ↓: Select Item
Enter>Select
F1   General Help
F2   Previous Values
F3   Optimized Defaults
F4   Save
ESC  Exit

Version 2.20.1271. Copyright (C) 2019 American Megatrends, Inc.
  
```

#### BIOS Menu 3: CPU Configuration

##### ➔ Intel® (VMX) Virtualization Technology [Disabled]

Use the **Intel® (VMX) Virtualization Technology** option to enable or disable virtualization on the system. When combined with third party software, Intel® Virtualization technology allows several OSs to run on the same system at the same time.

- ➔ **Disabled**      **DEFAULT**      Disables Intel® Virtualization Technology.
- ➔ **Enabled**        Enables Intel® Virtualization Technology.

**→ Active Processor Cores [All]**

Use the **Active Processor Cores** BIOS option to enable numbers of cores in the processor package.

- **All**      **DEFAULT**      Enable all cores in the processor package.
- **1**                      Enable one core in the processor package.
- **2**                      Enable two cores in the processor package.
- **3**                      Enable three cores in the processor package.

**→ Hyper-threading [Enabled]**

Use the **Hyper-threading** BIOS option to enable or disable the Intel Hyper-Threading Technology.

- **Disabled**                      Disables the Intel Hyper-Threading Technology.
- **Enabled**      **DEFAULT**      Enables the Intel Hyper-Threading Technology.

**→ Intel® SpeedStep™ [Enabled]**

Use the **Intel® SpeedStep™** option to enable or disable the Intel® SpeedStep Technology.

- **Disabled**                      Disables the Intel® SpeedStep Technology.
- **Enabled**      **DEFAULT**      Enables the Intel® SpeedStep Technology.

**→ C State [Disabled]**

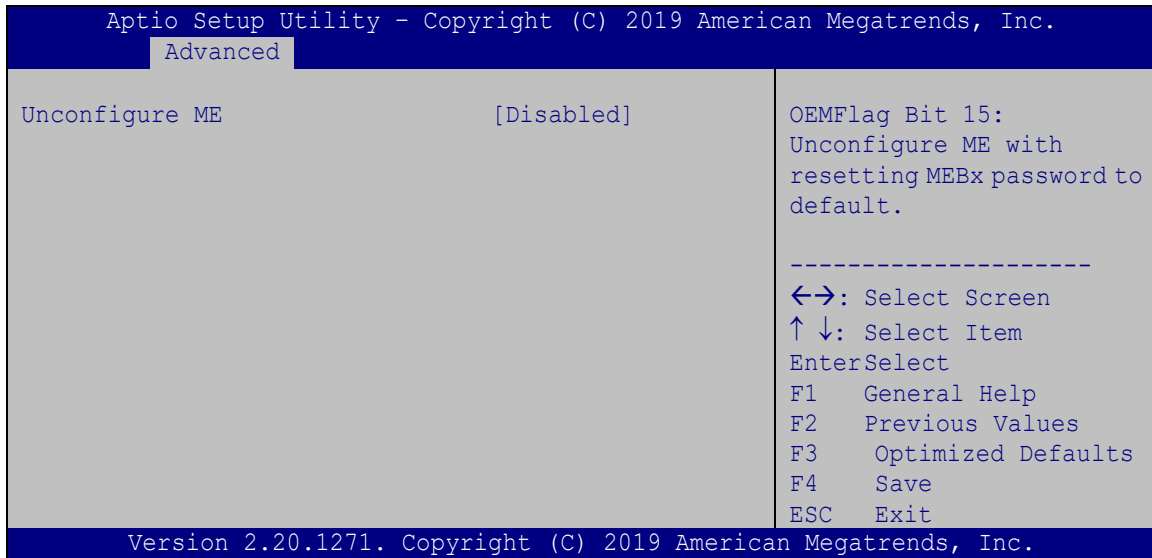
Use the **C State** option to enable or disable CPU C state.

- **Disabled**      **DEFAULT**      Disables CPU C state.
- **Enabled**                      Enables CPU C state.

## AFL3-W15C/W19C/W22C-ULT5 Panel PC

### 4.3.2 PCH-FW Configuration

The **PCH-FW Configuration** menu (**BIOS Menu 4**) allows Intel® Active Management Technology (AMT) options to be configured.



#### BIOS Menu 4: PCH-FW Configuration

##### → Unconfigure ME [Disabled]

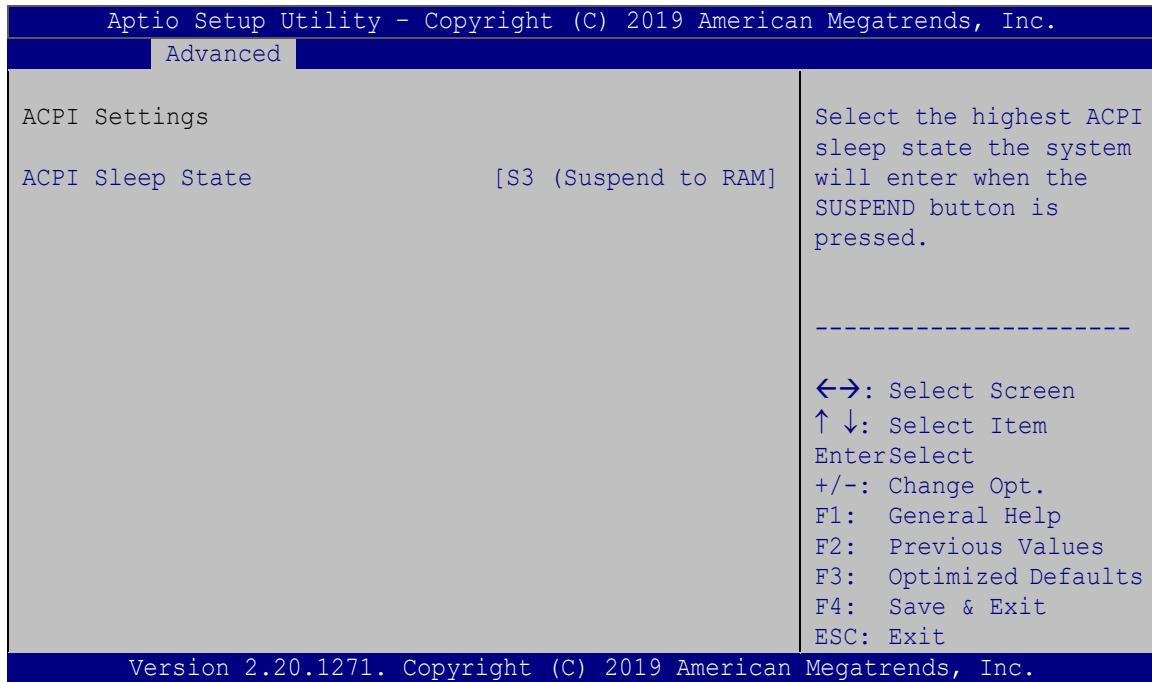
Use the **Unconfigure ME** option to perform ME unconfigure without password operation.

- **Disabled**      **DEFAULT**      Not perform ME unconfigure
- **Enabled**                      To perform ME unconfigure



### 4.3.3 ACPI Settings

The **ACPI Settings** menu (**BIOS Menu 5**) configures the Advanced Configuration and Power Interface (ACPI) options.



#### BIOS Menu 5: ACPI Settings

##### → **ACPI Sleep State [S3 (Suspend to RAM)]**

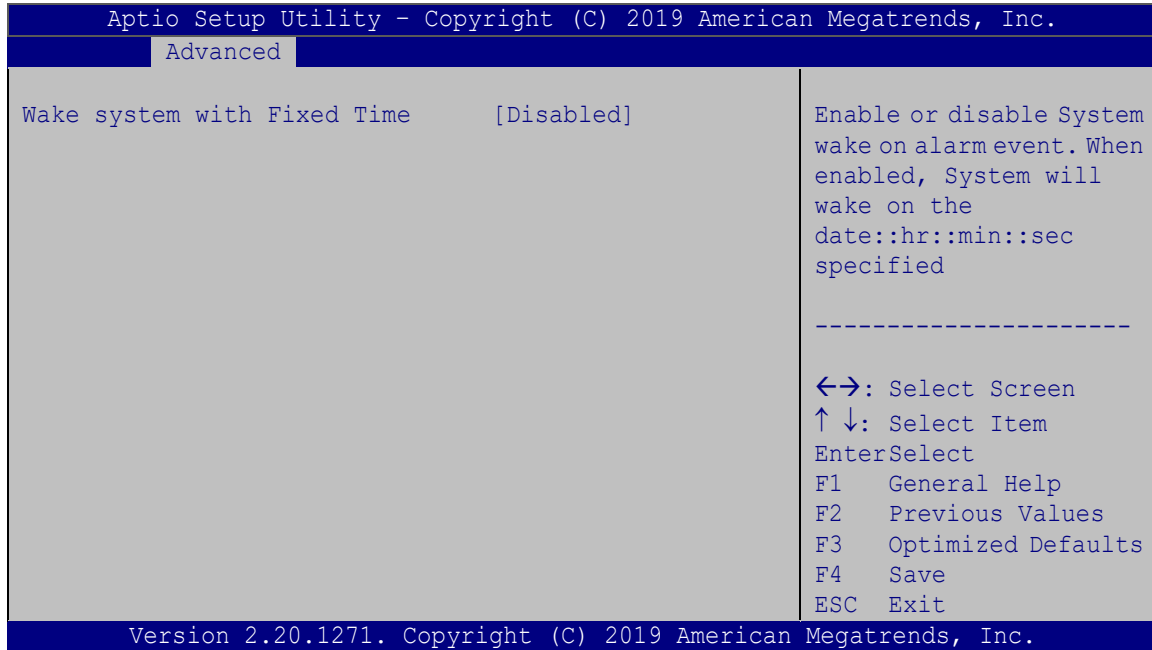
Use the **ACPI Sleep State** option to specify the sleep state the system enters when it is not being used.

- **S3 (Suspend to DEFAULT RAM)** The caches are flushed and the CPU is powered off. Power to the RAM is maintained. The computer returns slower to a working state, but more power is saved.

## AFL3-W15C/W19C/W22C-ULT5 Panel PC

### 4.3.4 RTC Wake Settings

The **RTC Wake Settings** menu (**BIOS Menu 6**) configures RTC wake event.



#### BIOS Menu 6: RTC Wake Settings

##### → Wake system with Fixed Time [Disabled]

Use the **Wake system with Fixed Time** option to enable or disable the system wake on alarm event.

→ **Disabled**      **DEFAULT**      The real time clock (RTC) cannot generate a wake event

→ **Enabled**      If selected, the **Wake up every day** option appears allowing you to enable to disable the system to wake every day at the specified time. Besides, the following options appear with values that can be selected:

Wake up date

Wake up hour

Wake up minute

Wake up second

After setting the alarm, the computer turns itself on from a suspend state when the alarm goes off.

### 4.3.5 iWDD H/W Monitor

The **iWDD H/W Monitor** menu (**BIOS Menu 7**) contains the fan configuration submenus and displays operating temperature, fan speeds and system voltages.

```

Aptio Setup Utility - Copyright (C) 2019 American Megatrends, Inc.
-----
Advanced
-----
PC Health Status

CPU temperature           :+31 °C
System temperature       :+29 °C

+VCCCORE                 :+0.756 V
+VDDQ                    :+1.219 V
+V3.3S                   :+3.416 V
+V3.3A                   :+3.416 V
+V1.05A                  :+1.038 V
+VCCSA                   :+0.715 V

-----
<->: Select Screen
↑ ↓: Select Item
Enter>Select
+ - Change Opt.
F1  General Help
F2  Previous Values
F3  Optimized Defaults
F4  Save & Exit
ESC Exit

Version 2.20.1271. Copyright (C) 2019 American Megatrends, Inc.
    
```

#### BIOS Menu 7: iWDD H/W Monitor

##### → PC Health Status

The following system parameters and values are shown. The system parameters that are monitored are:

- System Temperatures:
  - CPU Temperature
  - System temperature
- Voltages
  - +VCCCORE
  - +VDDQ
  - +V3.3S

## AFL3-W15C/W19C/W22C-ULT5 Panel PC

- +V3.3A
- +V1.05A
- +VCCSA

### 4.3.6 F81866 Super IO Configuration

Use the **F81866 Super IO Configuration** menu (**BIOS Menu 8**) to set or change the configurations for the serial ports.

```

Aptio Setup Utility - Copyright (C) 2019 American Megatrends, Inc.
  Advanced
F81866 Super IO Configuration
Super IO Chip                      F81866
> Serial Port 1 Configuration
> Serial Port 2 Configuration

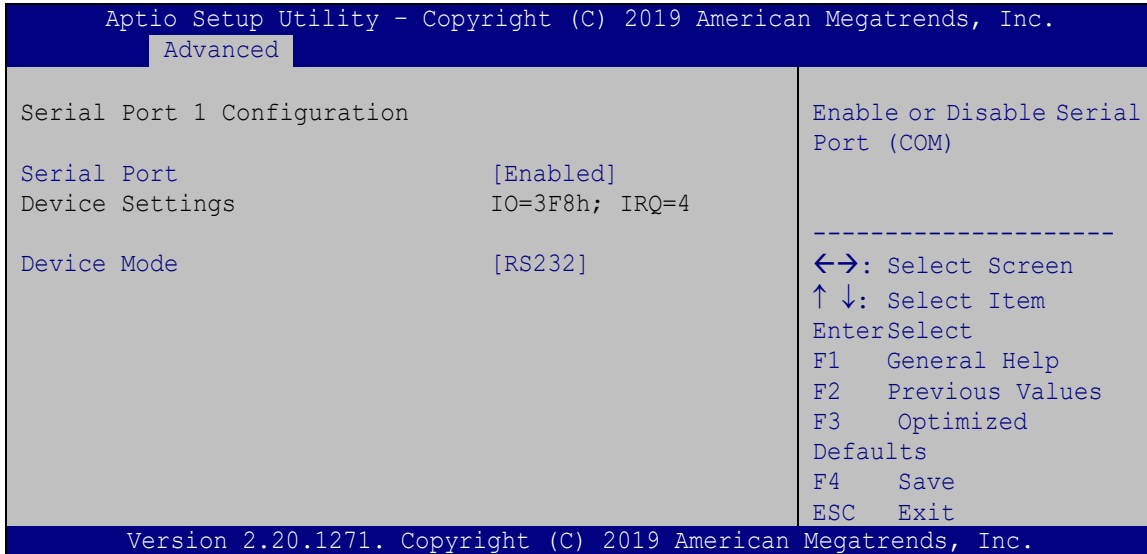
Set Parameters of Serial
Port 1 (COMA)
-----
<=>: Select Screen
↑ ↓: Select Item
Enter>Select
F1   General Help
F2   Previous Values
F3   Optimized
Defaults
F4   Save
ESC  Exit

Version 2.20.1271. Copyright (C) 2019 American Megatrends, Inc.
  
```

#### BIOS Menu 8: F81866 Super IO Configuration

### 4.3.6.1 Serial Port n Configuration

Use the **Serial Port n Configuration** menu (**BIOS Menu 9**) to configure the serial port n.



#### BIOS Menu 9: Serial Port n Configuration

#### 4.3.6.1.1 Serial Port 1 Configuration

##### → Serial Port [Enabled]

Use the **Serial Port** option to enable or disable the serial port.

- **Disabled** Disable the serial port
- **Enabled** **DEFAULT** Enable the serial port

##### → Device Mode [RS232]

Use the **Device Mode** option to select the Serial Port 1 signaling mode.

- **RS422** Serial Port 1 signaling mode is RS-422
- **RS232** **DEFAULT** Serial Port 1 signaling mode is RS-232
- **RS485** Serial Port 1 signaling mode is RS-485





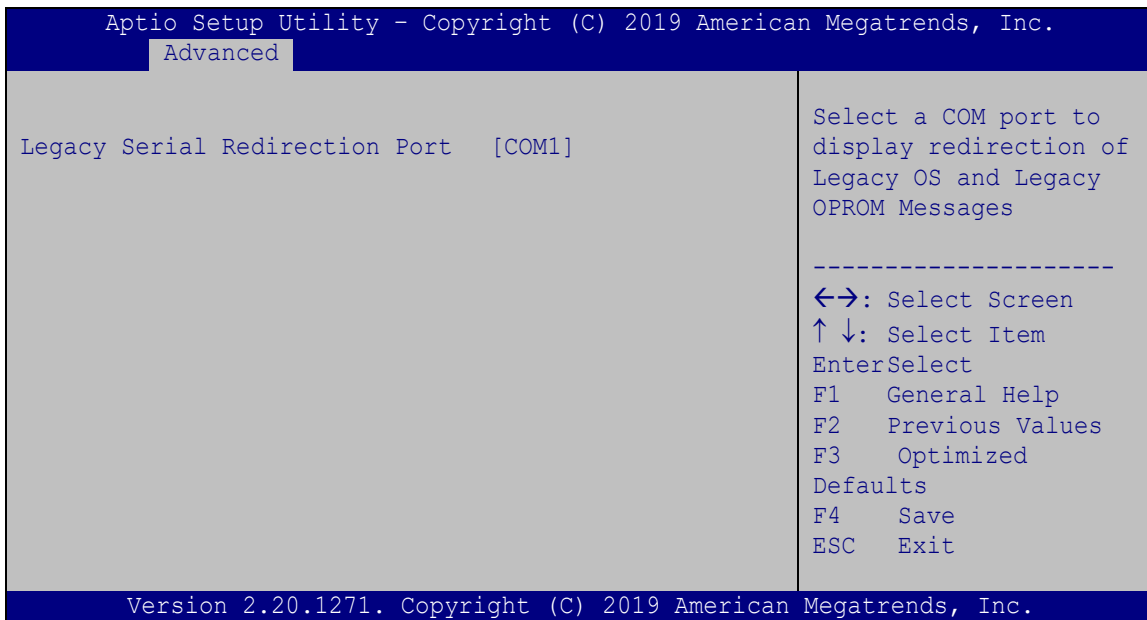
➔ **Console Redirection [Disabled]**

Use **Console Redirection** option to enable or disable the console redirection function.

- ➔ **Disabled**      **DEFAULT**      Disabled the console redirection function
- ➔ **Enabled**                      Enabled the console redirection function

**4.3.7.1 Legacy Console Redirection Settings**

The **Legacy Console Redirection Settings** menu (**BIOS Menu 11**) allows the legacy console redirection options to be configured.



**BIOS Menu 11: Legacy Console Redirection Settings**

➔ **Legacy Serial Redirection Port [COM1]**

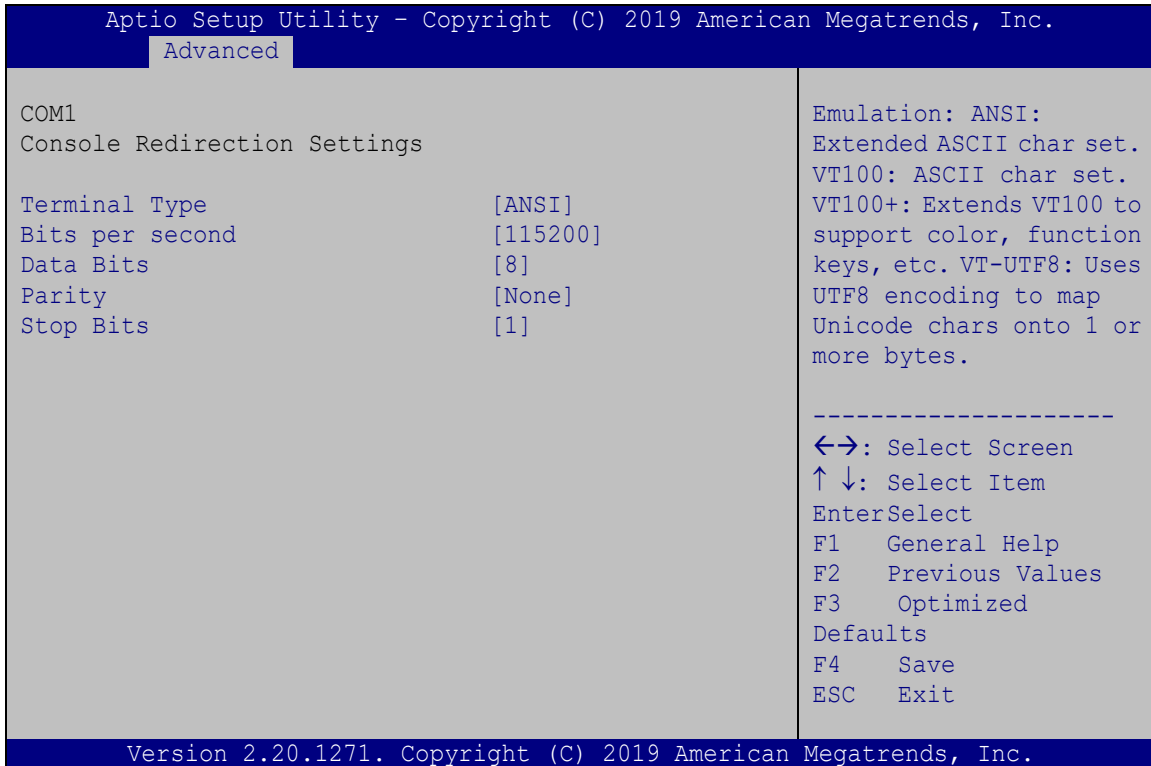
Use the **Legacy Serial Redirection Port** option to specify a COM port to display redirection of legacy OS and legacy OPRM messages. The options include:

- COM1                      **DEFAULT**
- COM2
- COM3 Pci Bus0, Dev0, Func0) (Disabled)

## AFL3-W15C/W19C/W22C-ULT5 Panel PC

### 4.3.7.2 Console Redirection Settings

The **Console Redirection Settings** menu (**BIOS Menu 12**) allows the console redirection options to be configured. The option is active when **Console Redirection** option is enabled.



#### BIOS Menu 12: Console Redirection Settings

##### ➔ Terminal Type [ANSI]

Use the **Terminal Type** option to specify the remote terminal type.

- ➔ **VT100**                      The target terminal type is VT100
- ➔ **VT100+**                    The target terminal type is VT100+
- ➔ **VT-UTF8**                    The target terminal type is VT-UTF8
- ➔ **ANSI**                      **DEFAULT**                    The target terminal type is ANSI

**→ Bits per second [115200]**

Use the **Bits per second** option to specify the serial port transmission speed. The speed must match the other side. Long or noisy lines may require lower speeds.

- |                 |                |  |
|-----------------|----------------|--|
| <b>→ 9600</b>   |                | Sets the serial port transmission speed at 9600.   |
| <b>→ 19200</b>  |                | Sets the serial port transmission speed at 19200.  |
| <b>→ 57600</b>  |                | Sets the serial port transmission speed at 57600.  |
| <b>→ 115200</b> | <b>DEFAULT</b> | Sets the serial port transmission speed at 115200. |

**→ Data Bits [8]**

Use the **Data Bits** option to specify the number of data bits.

- |            |                |                          |
|------------|----------------|--------------------------|
| <b>→ 7</b> |                | Sets the data bits at 7. |
| <b>→ 8</b> | <b>DEFAULT</b> | Sets the data bits at 8. |

**→ Parity [None]**

Use the **Parity** option to specify the parity bit that can be sent with the data bits for detecting the transmission errors.

- |                |                |   |
|----------------|----------------|---|
| <b>→ None</b>  | <b>DEFAULT</b> | No parity bit is sent with the data bits.                                 |
| <b>→ Even</b>  |                | The parity bit is 0 if the number of ones in the data bits is even.       |
| <b>→ Odd</b>   |                | The parity bit is 0 if the number of ones in the data bits is odd.        |
| <b>→ Mark</b>  |                | The parity bit is always 1. This option does not provide error detection. |
| <b>→ Space</b> |                | The parity bit is always 0. This option does not provide error detection. |

## AFL3-W15C/W19C/W22C-ULT5 Panel PC

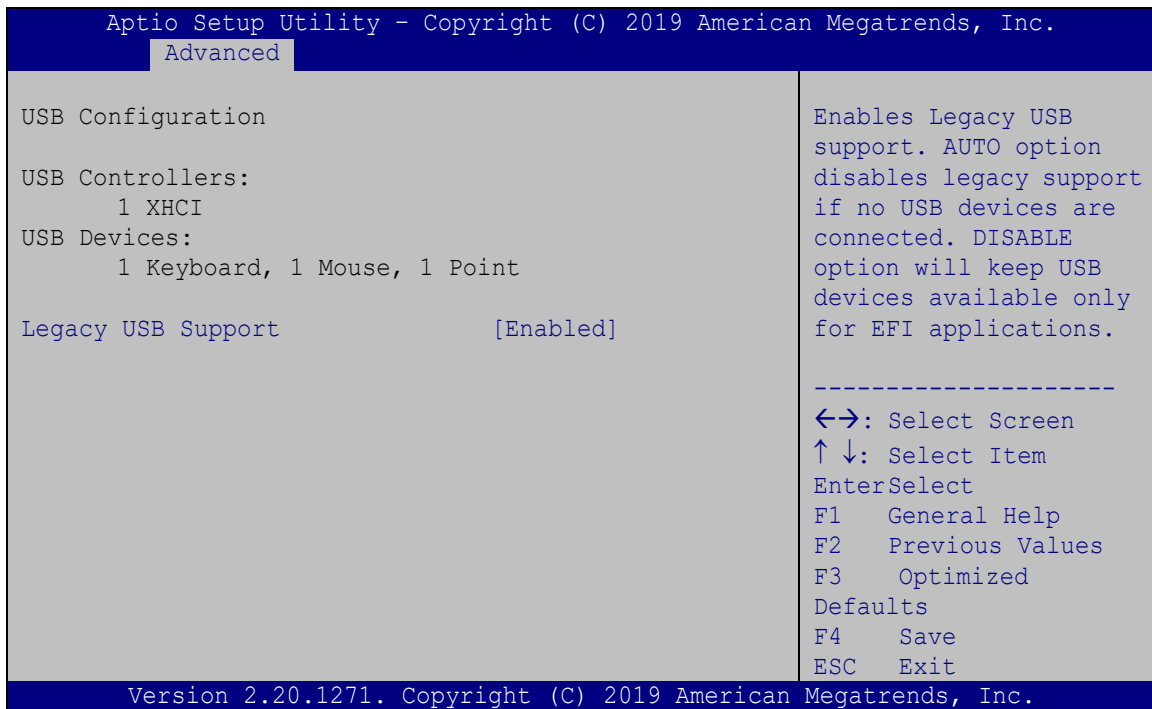
### → Stop Bits [1]

Use the **Stop Bits** option to specify the number of stop bits used to indicate the end of a serial data packet. Communication with slow devices may require more than 1 stop bit.

- 1                    **DEFAULT**        Sets the number of stop bits at 1.
- 2    Sets the number of stop bits at 2.

### 4.3.8 USB Configuration

Use the **USB Configuration** menu (**BIOS Menu 13**) to read USB configuration information and configure the USB settings.



#### BIOS Menu 13: USB Configuration

### → USB Devices

The **USB Devices Enabled** field lists the USB devices that are enabled on the system



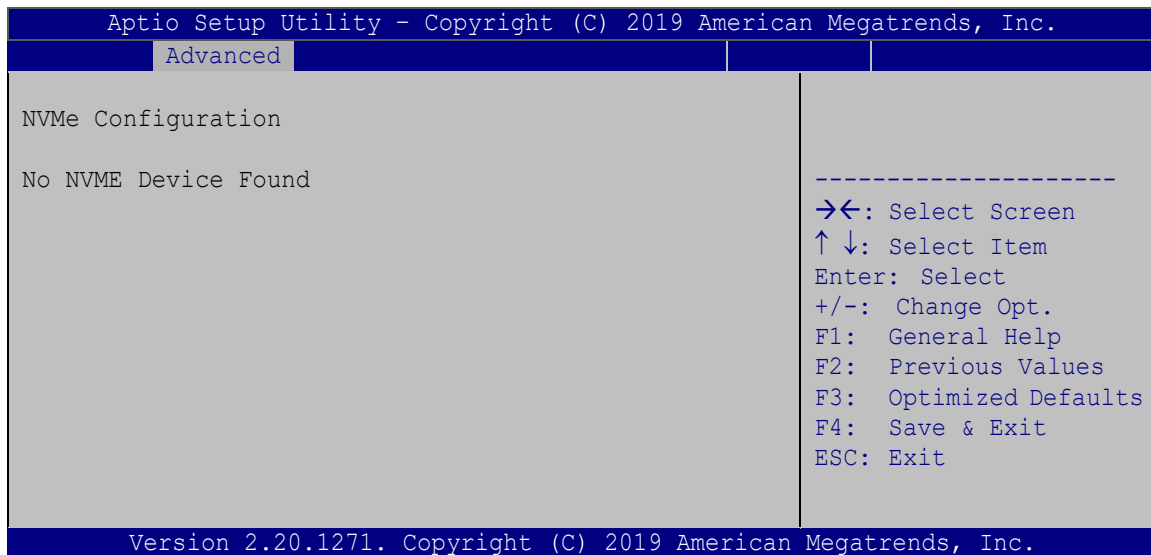
### → Legacy USB Support [Enabled]

Use the **Legacy USB Support** BIOS option to enable USB mouse and USB keyboard support. Normally if this option is not enabled, any attached USB mouse or USB keyboard does not become available until a USB compatible operating system is fully booted with all USB drivers loaded. When this option is enabled, any attached USB mouse or USB keyboard can control the system even when there is no USB driver loaded onto the system.

- **Enabled**      **DEFAULT**      Legacy USB support enabled
- **Disabled**                      Legacy USB support disabled
- **Auto**                              Legacy USB support disabled if no USB devices are connected

### 4.3.9 NVMe Configuration

Use the **NVMe Configuration (BIOS Menu 14)** menu to display the NVMe controller and device information.



**BIOS Menu 14: NVMe Configuration**



## 4.4 Chipset

Use the **Chipset** menu (**BIOS Menu 16**) to configure the system chipset.

```

Aptio Setup Utility - Copyright (C) 2019 American Megatrends, Inc.
Main   Advanced  Chipset   Security  Boot   Save & Exit

> System Agent (SA) Configuration
> PCH-IO Configuration

System Agent (SA)
Parameters

-----
<-->: Select Screen
↑ ↓: Select Item
Enter>Select
+ -   Change Opt.
F1   General Help
F2   Previous Values
F3   Optimized Defaults
F4   Save & Exit
ESC  Exit

Version 2.20.1271. Copyright (C) 2019 American Megatrends, Inc.
    
```

**BIOS Menu 16: Chipset**

### 4.4.1 System Agent (SA) Configuration

Use the **System Agent (SA) Configuration** menu (**BIOS Menu 17**) to configure the System Agent (SA) parameters.

```

Aptio Setup Utility - Copyright (C) 2019 American Megatrends, Inc.
Chipset

System Agent (SA) Configuration
VT-d                               Supported

> Memory Configuration
> Graphics Configuration

VT-d                               [Disabled]

Memory Configuration
Parameters

-----
<-->: Select Screen
↑ ↓: Select Item
Enter>Select
+ -   Change Opt.
F1   General Help
F2   Previous Values
F3   Optimized Defaults
F4   Save & Exit
ESC  Exit

Version 2.20.1271. Copyright (C) 2019 American Megatrends, Inc.
    
```

**BIOS Menu 17: System Agent (SA) Configuration**

## AFL3-W15C/W19C/W22C-ULT5 Panel PC

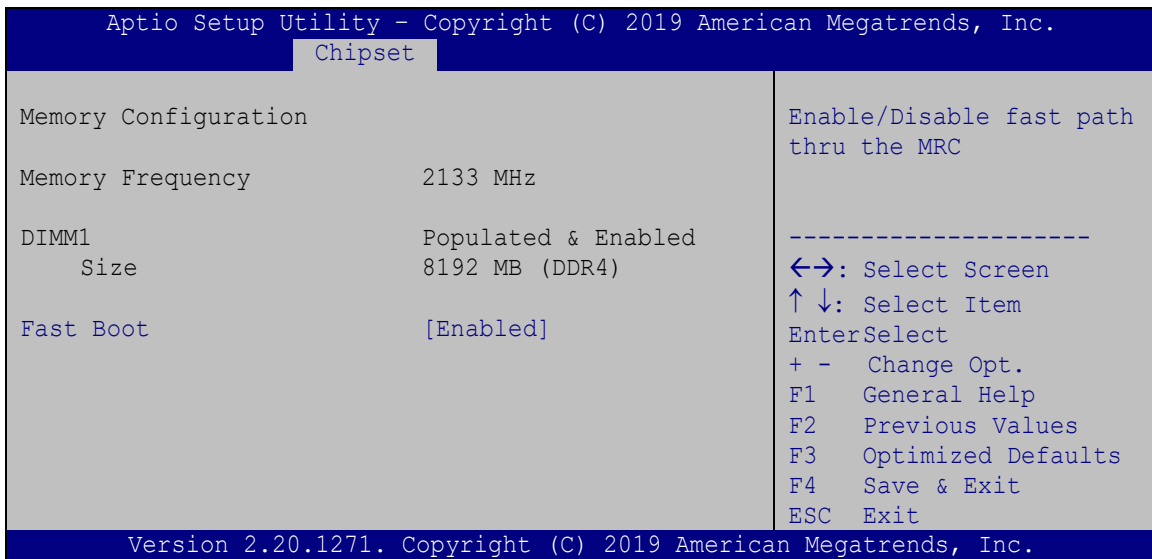
### → VT-d [Disabled]

Use the **VT-d** option to enable or disable VT-d support.

- **Disabled**    **DEFAULT**    Disable VT-d support.
- **Enabled**                    Enable VT-d support.

### 4.4.1.1 Memory Configuration

Use the **Memory Configuration** submenu (**BIOS Menu 18**) to display the memory information.



### BIOS Menu 18: Memory Configuration

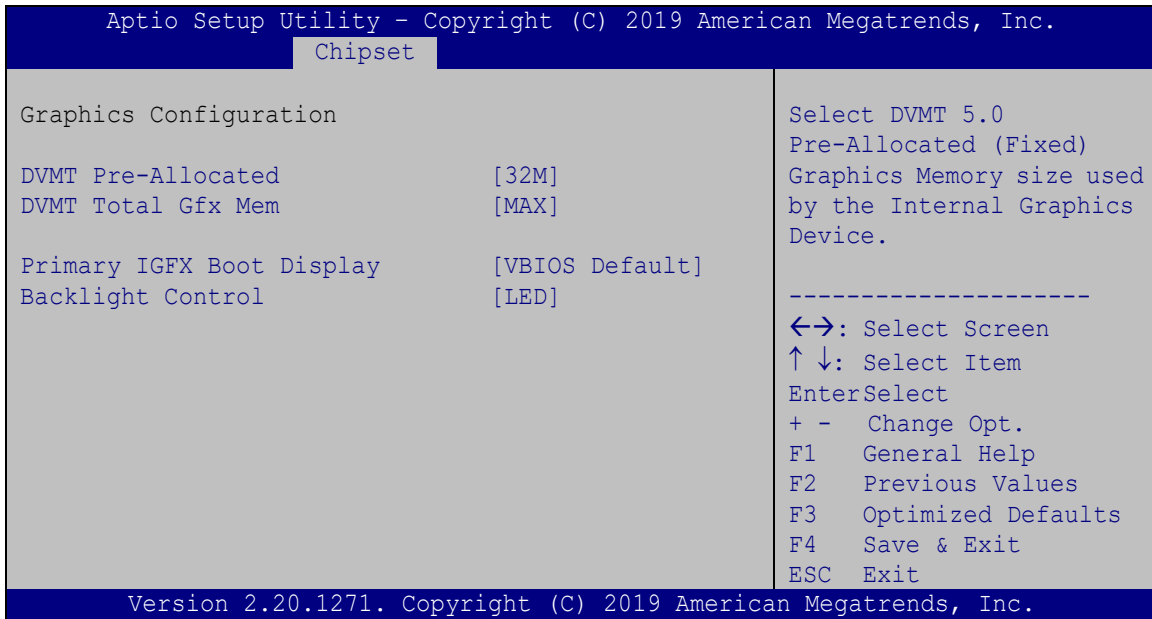
### → Fast Boot [Enabled]

Use the **Fast Boot** option to enable or disable the fast boot feature.

- **Disabled**                    Disable fast boot.
- **Enabled**    **DEFAULT**    Enable fast boot.

### 4.4.1.2 Graphics Configuration

Use the **Graphics Configuration** menu (**BIOS Menu 19**) to configure the graphics settings.



#### BIOS Menu 19: Graphics Configuration

##### → DVMT Pre-Allocated [32M]

Use the **DVMT Pre-Allocated** option to set the amount of system memory allocated to the integrated graphics processor when the system boots. The system memory allocated can then only be used as graphics memory, and is no longer available to applications or the operating system. Configuration options are listed below:

- 32M                    **DEFAULT**
- 64M

##### → DVMT Total Gfx Mem [MAX]

Use the **DVMT Total Gfx Mem** option to select DVMT 5.0 total graphic memory size used by the internal graphics device. The following options are available:

- 128M
- 256M



## AFL3-W15C/W19C/W22C-ULT5 Panel PC

- MAX                      **DEFAULT**

### → Primary IGFX Boot Display [VBIOS Default]

Use the **Primary IGFX Boot Display** option to select the display device used by the system when it boots.

- VBIOS Default    **DEFAULT**
- HDMI1
- LVDS

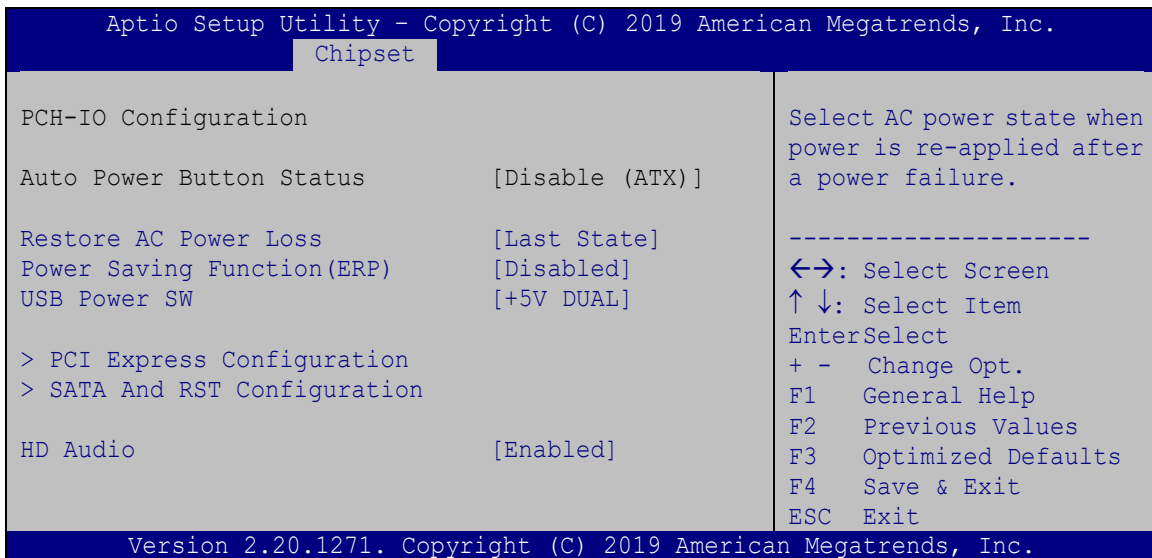
### → Backlight Control [LED]

Use the **Backlight Control** option to specify the backlight control mode. Configuration options are listed below.

- LED                      **DEFAULT**
- CCFL

## 4.4.2 PCH-IO Configuration

Use the **PCH-IO Configuration** menu (**BIOS Menu 20**) to configure the PCH-IO chipset.



**BIOS Menu 20: PCH-IO Configuration**

### → Restore AC Power Loss [Last State]

Use the **Restore AC Power** BIOS option to specify what state the system returns to if there is a sudden loss of power to the system.

- **Power Off**                      The system remains turned off
- **Power On**                      The system turns on
- **Last State**    **DEFAULT**    The system returns to its previous state. If it was on, it turns itself on. If it was off, it remains off.

### → Power Saving Function(ERP) [Disabled]

Use the **Power Saving Function(ERP)** BIOS option to enable or disable the power saving function.

- **Disabled**    **DEFAULT**    Power saving function is disabled.
- **Enabled**                      Power saving function is enabled. It will reduce power consumption when the system is off.

### → HD Audio [Enabled]

Use the **HD Audio** BIOS option to enable or disable the High Definition Audio controller.

- **Disabled**                      The High Definition Audio controller is disabled.
- **Enabled**    **DEFAULT**    The High Definition Audio controller is enabled.

### → USB Power SW [+5V DUAL]

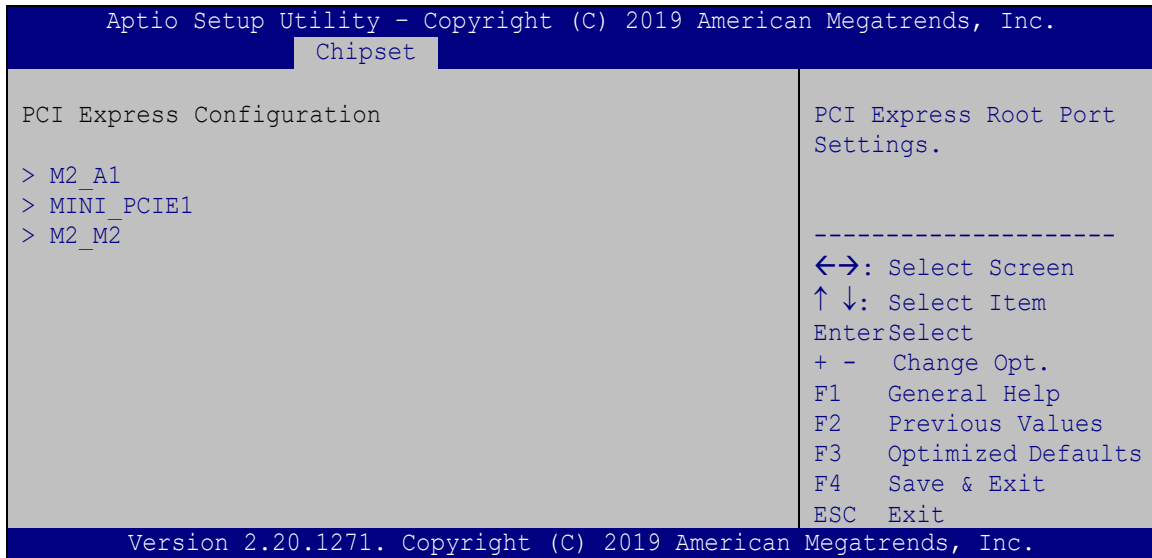
Use the **USB Power SW** BIOS option to configure whether to provide power to the USB connectors when the system is in S3/S4 sleep state. This option is valid only when the above **Power Saving Function (ERP)** BIOS option is disabled.

- **+5V**            **DEFAULT**    Power is provided to the USB connectors when the system is in S3/S4 sleep state
- **+5V**                      Power is not provided to the USB connectors when the system is in S3/S4 sleep state

## AFL3-W15C/W19C/W22C-ULT5 Panel PC

### 4.4.2.1 PCI Express Configuration

Use the **PCI Express Configuration** submenu (**BIOS Menu 21**) to configure the PCI Express slots.



#### BIOS Menu 21: PCI Express Configuration

The PCIe slot submenus all contain the following options:

#### → M2\_A1 / MINI\_PCIE1 / M2\_M2 [Enabled]

Use the **M2\_A1 / MINI\_PCIE1 / M2\_M2** option to enable or disable the PCIe Mini or M.2 expansion slot.

→ **Disabled** Disables the expansion slot.

→ **Enabled** **DEFAULT** Enables the expansion slot.

#### → PCIe Speed [Auto]

Use the **PCIe Speed** option to configure the PCIe interface speed.

- Auto **DEFAULT**
- Gen 1
- Gen 2
- Gen 3

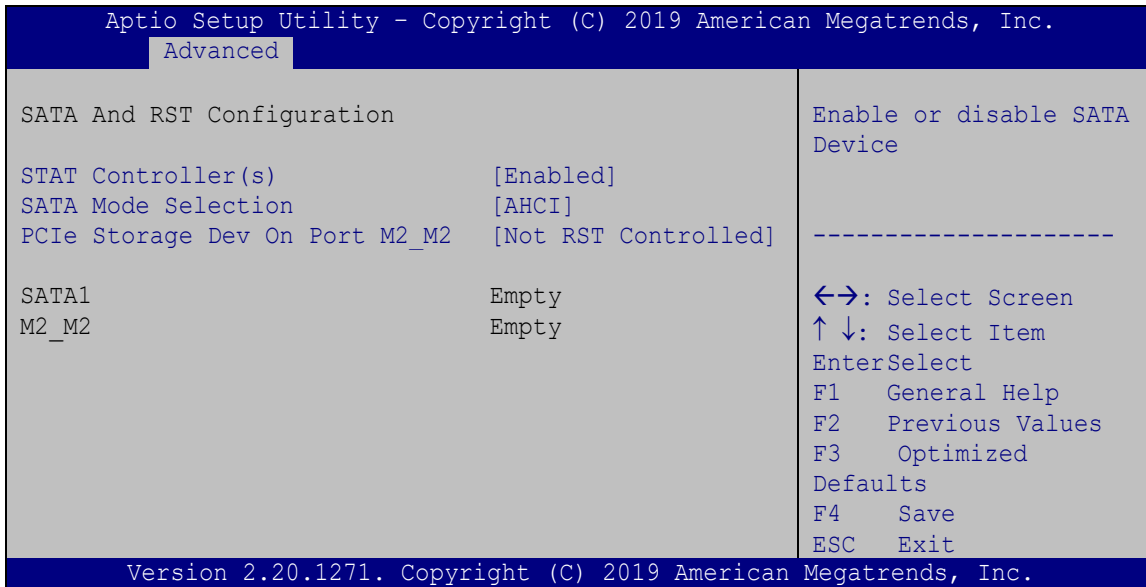
### → Detect Non-Compliance Device [Disabled]

Use the **Detect Non-Compliance Device** option to enable or disable detecting if a non-compliance PCI Express device is connected to the PCI Express slot.

- **Disabled**                      **DEFAULT**      Disables to detect if a non-compliance PCI Express device is connected to the PCI Express slot.
- **Enabled**                                      Enables to detect if a non-compliance PCI Express device is connected to the PCI Express slot.

### 4.4.2.2 SATA And RST Configuration

Use the **SATA And RST Configuration** menu (**BIOS Menu 22**) to change and/or set the configuration of the SATA devices installed in the system.



#### BIOS Menu 22: SATA and RST Configuration

### → STAT Controller(s) [Enabled]

Use the **STAT Controller(s)** option to enable or disable the SATA device.

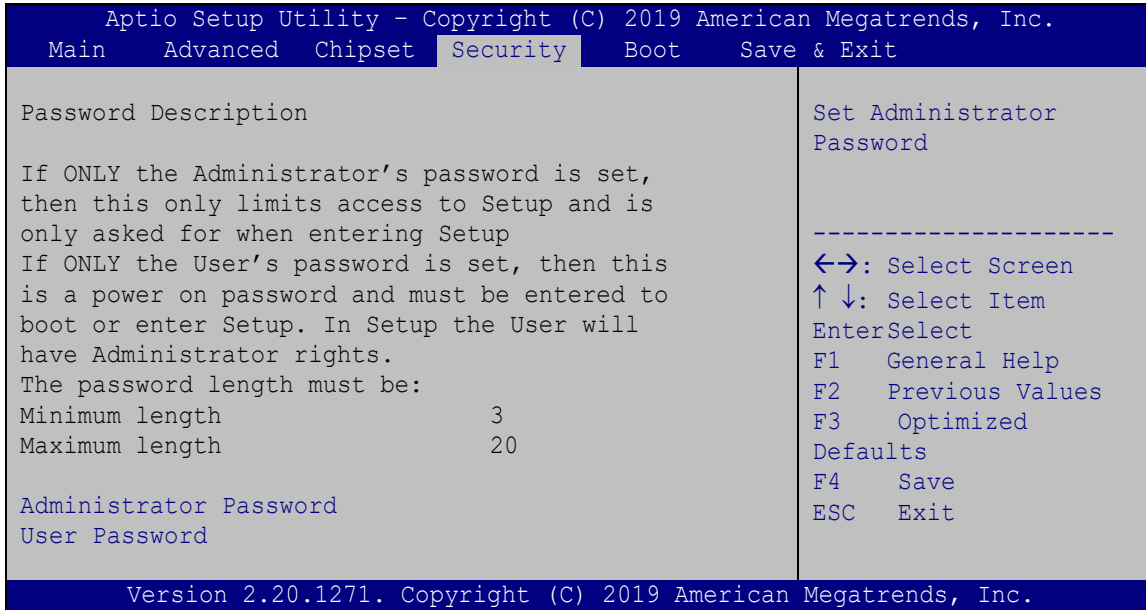
- **Enabled**                      **DEFAULT**      Enables the SATA device.
- **Disabled**                                      Disables the SATA device.





## 4.5 Security

Use the **Security** menu (**BIOS Menu 23**) to set system and user passwords.



### BIOS Menu 23: Security

#### → Administrator Password

Use the **Administrator Password** to set or change a administrator password.

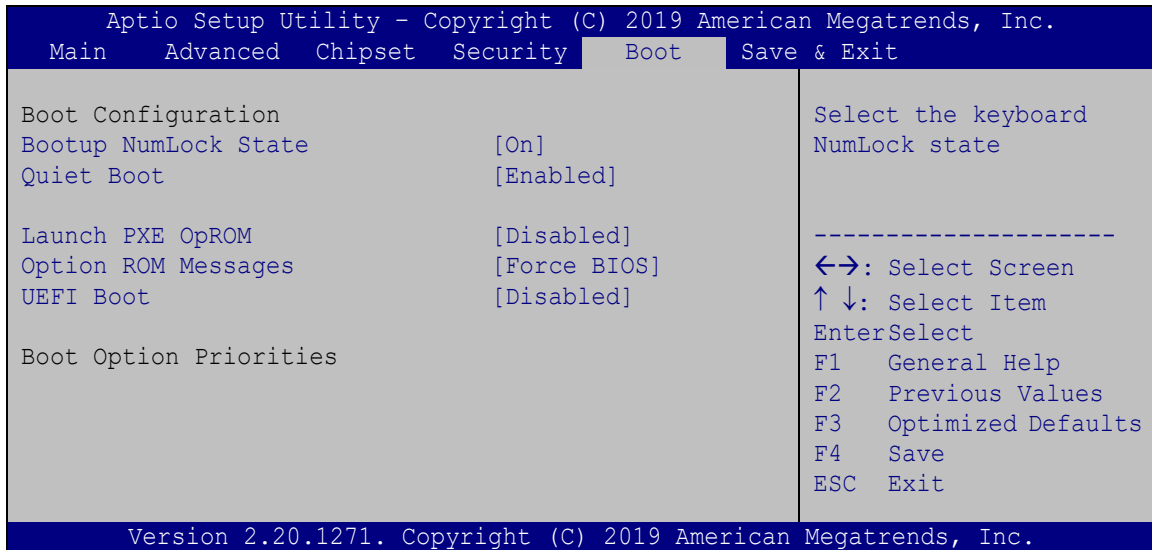
#### → User Password

Use the **User Password** to set or change a user password.

## AFL3-W15C/W19C/W22C-ULT5 Panel PC

### 4.6 Boot

Use the **Boot** menu (**BIOS Menu 24**) to configure system boot options.



#### BIOS Menu 24: Boot

##### → Bootup NumLock State [On]

Use the **Bootup NumLock State** BIOS option to specify if the number lock setting must be modified during boot up.

- **On**                      **DEFAULT**                      Allows the Number Lock on the keyboard to be enabled automatically when the computer system boots up. This allows the immediate use of the 10-key numeric keypad located on the right side of the keyboard. To confirm this, the Number Lock LED light on the keyboard is lit.
- **Off**                                      Does not enable the keyboard Number Lock automatically. To use the 10-keys on the keyboard, press the Number Lock key located on the upper left-hand corner of the 10-key pad. The Number Lock LED on the keyboard lights up when the Number Lock is engaged.

### → Quiet Boot [Enabled]

Use the **Quiet Boot** BIOS option to select the screen display when the system boots.

- **Disabled** Normal POST messages displayed
- **Enabled** **DEFAULT** OEM Logo displayed instead of POST messages

### → Launch PXE OpROM [Disabled]

Use the **Launch PXE OpROM** option to enable or disable boot option for legacy network devices.

- **Disabled** **DEFAULT** Ignore all PXE Option ROMs
- **Enabled** Load PXE Option ROMs.

### → Option ROM Messages [Force BIOS]

Use the **Option ROM Messages** option to set the Option ROM display mode.

- **Force BIOS** **DEFAULT** Sets display mode to force BIOS.
- **Keep Current** Sets display mode to current.

### → UEFI Boot [Disabled]

Use the **UEFI Boot** option to enable or disable to boot from the UEFI devices.

- **Enabled** Boot from UEFI devices is enabled.
- **Disabled** **DEFAULT** Boot from UEFI devices is disabled.

### → Boot Option Priority

Use the **Boot Option Priority** function to set the system boot sequence from the available devices. The drive sequence also depends on the boot sequence in the individual device section.

## AFL3-W15C/W19C/W22C-ULT5 Panel PC

## 4.7 Exit

Use the **Exit** menu (**BIOS Menu 25**) to load default BIOS values, optimal failsafe values and to save configuration changes.

```

Aptio Setup Utility - Copyright (C) 2019 American Megatrends, Inc.
Main  Advanced  Chipset  Security  Boot  Save & Exit
-----
Save Changes and Reset
Discard Changes and Reset

Restore Defaults
Save as User Defaults
Restore User Defaults

Reset the system after
saving the changes.

-----
<->: Select Screen
↑ ↓: Select Item
Enter>Select
F1   General Help
F2   Previous Values
F3   Optimized
Defaults
F4   Save
ESC  Exit

Version 2.20.1271. Copyright (C) 2019 American Megatrends, Inc.

```

**BIOS Menu 25: Exit**→ **Save Changes and Reset**

Use the **Save Changes and Reset** option to save the changes made to the BIOS options and to exit the BIOS configuration setup program.

→ **Discard Changes and Reset**

Use the **Discard Changes and Reset** option to exit the system without saving the changes made to the BIOS configuration setup program.

→ **Restore Defaults**

Use the **Restore Defaults** option to load the optimal default values for each of the parameters on the Setup menus. **F3 key can be used for this operation.**

→ **Save as User Defaults**

Use the **Save as User Defaults** option to save the changes done so far as user defaults.

→ **Restore User Defaults**

Use the **Restore User Defaults** option to restore the user defaults to all the setup options.



Chapter

**5**

# System Maintenance

---

## 5.1 System Maintenance Introduction

If the components of the AFL3-W15C/W19C/W22C-ULT5 fail they must be replaced. Please contact the system reseller or vendor to purchase the replacement parts. Back cover removal instructions for the AFL3-W15C/W19C/W22C-ULT5 are described below.

## 5.2 Anti-static Precautions



### WARNING:

Failure to take ESD precautions during the maintenance of the AFL3-W15C/W19C/W22C-ULT5 may result in permanent damage to the AFL3-W15C/W19C/W22C-ULT5 and severe injury to the user.

---

Electrostatic discharge (ESD) can cause serious damage to electronic components, including the AFL3-W15C/W19C/W22C-ULT5. Dry climates are especially susceptible to ESD. It is therefore critical that whenever the AFL3-W15C/W19C/W22C-ULT5 is accessed internally, or any other electrical component is handled, the following anti-static precautions are strictly adhered to.

- **Wear an anti-static wristband:** - Wearing a simple anti-static wristband can help to prevent ESD from damaging the board.
- **Self-grounding:** - Before handling the board touch any grounded conducting material. During the time the board is handled, frequently touch any conducting materials that are connected to the ground.
- **Use an anti-static pad:** - When configuring the AFL3-W15C/W19C/W22C-ULT5, place it on an anti-static pad. This reduces the possibility of ESD damaging the AFL3-W15C/W19C/W22C-ULT5.
- **Only handle the edges of the PCB:** - When handling the PCB, hold the PCB by the edges.

## AFL3-W15C/W19C/W22C-ULT5 Panel PC

### 5.3 Turn off the Power



#### **WARNING:**

Failing to turn off the system before opening it can cause permanent damage to the system and serious or fatal injury to the user.

Before any maintenance procedures are carried out on the system, make sure the system is turned off.

### 5.4 SO-DIMM Module Replacement

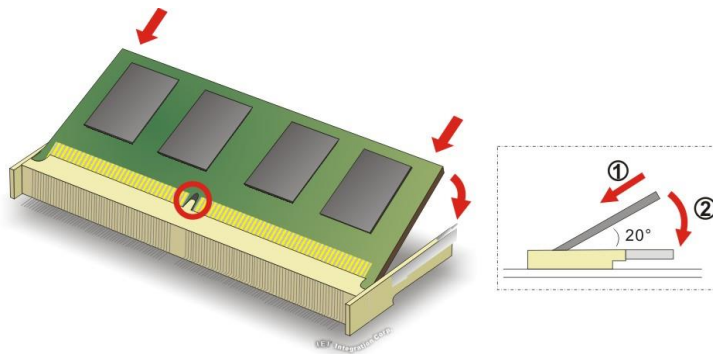
The AFL3-W15C/W19C/W22C-ULT5 has one SO-DIMM module installed. To replace the SO-DIMM module, follow the instructions below.

- Step 1:** Follow all anti-static procedures. See **Section 5.2**.
- Step 2:** Turn off the power. See Section 5.3.
- Step 3:** Remove the plastic back cover and the internal metal cover. See **Section 3.4** above.
- Step 4:** Locate the SO-DIMM module (Figure 5-1).



Figure 5-1: SO-DIMM module Location

- Step 5:** Remove the DDR4 memory module by pulling both the spring retainer clips outward from the socket.
- Step 6:** Grasp the DDR4 memory module by the edges and carefully pull it out of the socket.
- Step 7:** Install the new DDR4 memory module by pushing it into the socket at a 20° angle (**Figure 5-2**).
- Step 8:** Gently push the memory module downwards and the arms clip into place (**Figure 5-2**).



**Figure 5-2: SO-DIMM Installation**

- Step 9:** Reinstall the internal metal cover and the plastic back cover using the previously removed retention screws.



**WARNING:**

Failing to reinstall the cover may result in permanent damage to the system. Please make sure all coverings are properly installed.

---

Chapter

**6**

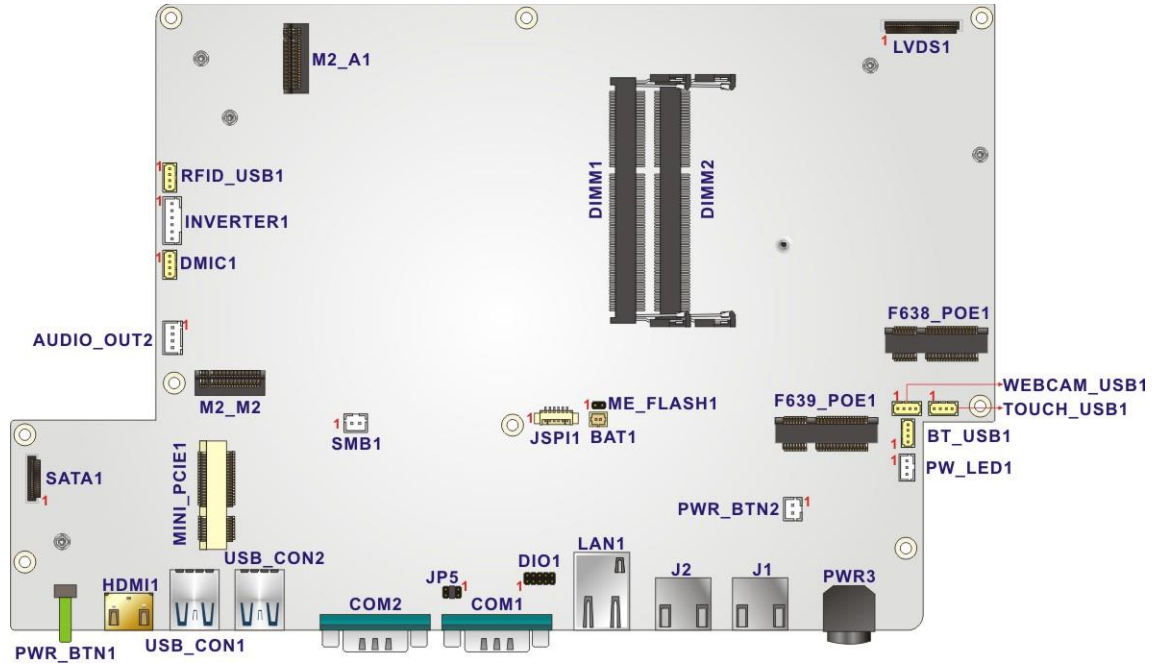
# Interface Connectors

---



## 6.1 Peripheral Interface Connectors

The AFL3-W15C/W19C/W22C-ULT5 panel PC motherboard comes with a number of peripheral interface connectors and configuration jumpers. The connector locations are shown in **Figure 6-1**. The Pin 1 locations of the on-board connectors are also indicated in the diagram below. The connector pinouts for these connectors are listed in the following sections.



**Figure 6-1: Main Board Layout Diagram**

## 6.2 Internal Peripheral Connectors

Internal peripheral connectors are found on the motherboard and are only accessible when the motherboard is outside of the chassis. The table below shows a list of the peripheral interface connectors on the motherboard. Pinouts of these connectors can be found in the following sections.

Connector	Type	Label
Audio out connector	4-pin wafer	AUDIO_OUT2
Battery connector	2-pin wafer	BAT1
Debug connector	12-pin wafer	DBG_PORT1
Digital I/O connector	10-pin header	DIO1
IEI PoE module slot	Full-size/Half-size PCIe Mini slot	F639_POE1
Inverter connector	6-pin wafer	INVERTER1
LVDS connector	30-pin crimp	LVDS1
M.2 slot (installed with WLAN module)	A-key slot	M2_A1
M.2 slot (support SSD)	M-key slot	M2_M2
Microphone connector	4-pin wafer	DMIC1
PCIe Mini card slot	Full-size	MINI_PCIE1
Power button connector	2-pin wafer	PWR_BTN1
Power LED connector	3-pin wafer	PW_LED1
SATA connector	7-pin connector	SATA1
SPI Flash connector	6-pin wafer	JSPI1
USB connectors	4-pin wafer	BT_USB1 TOUCH_USB1 RFID_USB1 WEBCAM_USB1

**Table 6-1: Peripheral Interface Connectors**

**6.2.1 Audio Out Connector (AUDIO\_OUT2)**

PIN NO.	DESCRIPTION
1	SPK_OUT_P_L
2	SPK_OUT_N_L
3	SPK_OUT_N_R
4	SPK_OUT_P_R

**Table 6-2: Audio Out Connector (AUDIO\_OUT2) Pinouts**

**6.2.2 Battery Connector (BAT1)**

PIN NO.	DESCRIPTION
1	VBATT
2	GND

**Table 6-3: Battery Connector (BAT1) Pinouts**

**6.2.3 Digital I/O Connector (DIO1)**

PIN NO.	DESCRIPTION	PIN NO.	DESCRIPTION
1	GND	2	+5V
3	DOUT3	4	DOUT2
5	DOUT1	6	DOUT0
7	DIN3	8	DIN2
9	DIN1	10	DIN0

**Table 6-4: Digital I/O Connector (DIO1) Pinouts**

**6.2.4 Inverter Connector (INVERTER1)**

PIN NO.	DESCRIPTION
1	+12V
2	+12V
3	ENABKL
4	BRIGHTNESS
5	GND
6	GND

**Table 6-5: Inverter Connector (INVERTER1) Pinouts**

**6.2.5 LVDS Connector (LVDS1)**

PIN NO.	DESCRIPTION	PIN NO.	DESCRIPTION
1	+VCC LCD	2	+VCC LCD
3	+VCC LCD	4	+VCC LCD
5	+VCC LCD	6	N/A
7	LVDS RESEST B	8	GND
9	GND	10	GND
11	GND	12	CLK2P_L
13	CLK2M_L	14	GND
15	A7P_L	16	A7M_L
17	GND	18	A6P_L
19	A6M_L	20	GND
21	A5P_L	22	A5M_L
23	GND	24	A4P_L
25	A4M_L	26	GND
27	A3P_L	28	A3M_L
29	GND	30	CLK1P_L
31	CLK1M_L	32	GND
33	A2P_L	34	A2M_L
35	GND	36	A1M_L
37	A1P_L	38	GND
39	A0M_L	40	A0P_L

**Table 6-6: LVDS Connector (LVDS1) Pinouts**

**6.2.6 M.2 A-Key Slot (M2\_A1)**

PIN NO.	DESCRIPTION	PIN NO.	DESCRIPTION
1	GND	2	+V3.3A
3	USB+	4	+V3.3A
5	USB-	6	NC
7	GND	8	Module Key
9	Module Key	10	Module Key
11	Module Key	12	Module Key
13	Module Key	14	Module Key
15	Module Key	16	NC
17	NC	18	GND
19	NC	20	NC
21	NC	22	NC
23	GND	24	GND
25	NC	26	NC
27	NC	28	NC
29	GND	30	GND
31	NC	32	NC
33	GND	34	NC
35	PCIE_TX+	36	GND
37	PCIE_TX-	38	NC
39	GND	40	NC
41	PCIE_RX+	42	NC
43	PCIE_RX-	44	NC
45	GND	46	NC
47	CLK_PCIE+	48	NC
49	CLK_PCIE-	50	NC
51	GND	52	BUF_PLT_RST#
53	NC	54	Pull Up +V3.3A
55	PCIE_WAKE#	56	Pull Up +V3.3A
57	GND	58	SMB_DATA
59	NC	60	SMB_CLK



## AFL3-W15C/W19C/W22C-ULT5 Panel PC

61	NC	62	NC
63	GND	64	NC
65	NC	66	NC
67	NC	68	NC
69	GND	70	NC
71	NC	72	+V3.3A
73	NC	74	+V3.3A
75	GND		

**Table 6-7: M.2 A-Key Slot (M2\_A1) Pinouts**

### 6.2.7 M.2 M-key Slot (M2\_M2)

PIN NO.	DESCRIPTION	PIN NO.	DESCRIPTION
1	GND	2	+3.3VA
3	GND	4	+3.3VA
5	PCIE_RX-	6	N/C
7	PCIE_RX+	8	N/C
9	GND	10	+3.3VA
11	PCIE_TX-	12	+3.3VA
13	PCIE_TX+	14	+3.3VA
15	GND	16	+3.3VA
17	PCIE_RX-	18	+3.3VA
19	PCIE_RX+	20	N/C
21	GND	22	N/C
23	PCIE_TX-	24	N/C
25	PCIE_TX+	26	N/C
27	GND	28	N/C
29	PCIE_RX-	30	N/C
31	PCIE_RX+	32	N/C
33	GND	34	N/C
35	PCIE_TX-	36	N/C
37	PCIE_TX+	38	SATA_SLP

39	GND	40	N/C
41	PCIE_RX+	42	N/C
43	PCIE_RX-	44	N/C
45	GND	46	N/C
47	PCIE_TX-	48	N/C
49	PCIE_TX+	50	PCIE_RST#
51	GND	52	PCIE_CLKREQ
53	CLK_PCIE_M2_M-	54	LAN_WAKE#
55	CLK_PCIE_M2_M+	56	N/C
57	GND	58	N/C
59	N/C	60	N/C
61	N/C	62	N/C
63	N/C	64	N/C
65	N/C	66	N/C
67	N/C	68	N/C
69	M2_IFDET	70	+3.3VA
71	GND	72	+3.3VA
73	GND	74	+3.3VA
75	GND		

**Table 6-8: M.2 M-key Slot (M2\_M2) Pinouts**

### 6.2.8 Microphone Connector (DMIC1)

PIN NO.	DESCRIPTION
1	DMIC_CLK
2	DMIC_DATA
3	+3.3V
4	GND

**Table 6-9: Microphone Connector (DMIC1) Pinouts**

**6.2.9 PCIe Mini Connector, Full-size (MINI\_PCIE1)**

PIN NO.	DESCRIPTION	PIN NO.	DESCRIPTION
1	PCIE_WAKE#	2	+3.3V
3	N/C	4	GND
5	N/C	6	+1.5V
7	N/C	8	N/C
9	GND	10	N/C
11	CLK-	12	N/C
13	CLK+	14	N/C
15	GND	16	N/C
17	N/C	18	GND
19	N/C	20	+3.3V
21	GND	22	PCIRST#
23	PCIE_RX-	24	3VDual
25	PCIE_RX+	26	GND
27	GND	28	+1.5V
29	GND	30	SMBCLK
31	PCIE_TX-	32	SMBDATA
33	PCIE_TX+	34	GND
35	GND	36	USBD-
37	GND	38	USBD+
39	+3.3V	40	GND
41	+3.3V	42	N/C
43	GND	44	RF_LINK#
45	N/C	46	BLUELED#
47	N/C	48	+1.5V
49	N/C	50	GND
51	N/C	52	+3.3V

**Table 6-10: Full-size PCIe Mini Connector (MINI\_PCIE1) Pinouts**

### 6.2.10 Power Button Connector (PW\_BTN1)

PIN NO.	DESCRIPTION
1	PW_BN
2	GND

**Table 6-11: Power Button Connector (PW\_BTN1) Pinouts**

### 6.2.11 Power LED Connector (PW\_LED1)

PIN NO.	DESCRIPTION
1	PW_LED +5V
2	GND
3	SUS PW LED +5V

**Table 6-12: Power LED Connector (PW\_LED1) Pinouts**

### 6.2.12 SATA Connector (SATA1)

PIN NO.	DESCRIPTION
1	GND
2	TX+
3	TX-
4	GND
5	RX-
6	RX+
7	GND

**Table 6-13: SATA Connector (SATA1) Pinouts**

## AFL3-W15C/W19C/W22C-ULT5 Panel PC

### 6.2.13 SPI Flash Connector (JSPI1)

PIN NO.	DESCRIPTION
1	+V3.3M_SPI_CON
2	SPI_CS#0_CN
3	SPI_SO_SW
4	SPI_CLK_SW
5	SPI_SI_SW
6	GND

**Table 6-14: SPI Flash Connector (JSPI1) Pinouts**

### 6.2.14 USB Connector (BT\_USB1)

PIN NO.	DESCRIPTION
1	+V5A
2	HUB_D1F-
3	HUB_D1F+
4	GND

**Table 6-15: USB Connector (BT\_USB1) Pinouts**

### 6.2.15 USB Connector (TOUCH\_USB1)

PIN NO.	DESCRIPTION
1	+V5A
2	HUB_D2F-
3	HUB_D2F+
4	GND

**Table 6-16: USB Connector (TOUCH\_USB1) Pinouts**



### 6.2.16 USB Connector (RFID\_USB1)

PIN NO.	DESCRIPTION
1	+V5A
2	HUB_D3F-
3	HUB_D3F+
4	GND

Table 6-17: USB Connector (RFID\_USB1) Pinouts

### 6.2.17 USB Connector (WEBCAM\_USB1)

PIN NO.	DESCRIPTION
1	+V5A
2	HUB_D4F-
3	HUB_D4F+
4	GND

Table 6-18: USB Connector (CAM\_USB1) Pinouts

## 6.3 External Interface Panel Connectors

The table below lists the rear panel connectors on the AFL3MB-ULT5 motherboard. Pinouts of these connectors can be found in the following sections.

Connector	Type	Label
Ethernet connector	RJ-45	LAN1
Ethernet connector with PoE	RJ-45	J1, J2
HDMI connector	HDMI connector	HDMI1
Power connector	Power jack	PWR3
RS-232 serial port	D-sub 9	COM2
RS-232/422/485 serial port	D-sub 9	COM1

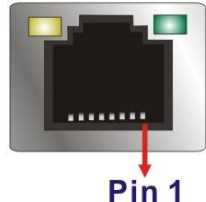
**AFL3-W15C/W19C/W22C-ULT5 Panel PC**

Connector	Type	Label
USB 3.2 Gen 2 connectors	USB 3.2 Gen 2 port	USB_CON1 USB_CON2

**Table 6-19: Rear Panel Connectors**

**6.3.1 Ethernet Connectors (LAN1, J1, J2)**

PIN NO.	DESCRIPTION	PIN NO.	DESCRIPTION
1	MDIA0+	5	MDIA2-
2	MDIA0-	6	MDIA1-
3	MDIA1+	7	MDIA3+
4	MDIA2+	8	MDIA3-



**Table 6-20: Ethernet Connectors (LAN1, J1, J2) Pinouts**

LED	Description	LED	Description
A	on: linked blinking: data is being sent/received	B	off: 10 Mb/s green: 100 Mb/s orange: 1000 Mb/s

**Table 6-21: Ethernet Connector LEDs**

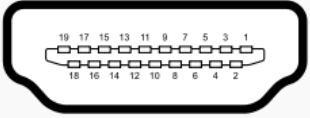
**6.3.2 Power Connector (PWR3)**



**Table 6-22: Power Connector (PWR1) Pinouts**

**6.3.3 HDMI Connector (HDMI1)**

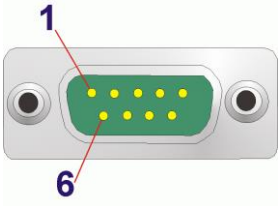
PIN NO.	DESCRIPTION	PIN NO.	DESCRIPTION
1	HDMI_DATA2+	11	GND
2	GND	12	HDMI_CLK#
3	HDMI_DATA2#-	13	N/C
4	HDMI_DATA1+	14	N/C
5	GND	15	HDMI_SCL
6	HDMI_DATA1#-	16	HDMI_SDA
7	HDMI_DATA0+	17	GND
8	GND	18	+5VCC
9	HDMI_DATA0#-	19	HDMI_HPD
10	HDMI_CLK+		



**Table 6-23: HDMI Connector (HDMI1) Pinouts**

**6.3.4 RS-232/422/485 DB-9 Serial Port (COM1)**

Pin	RS-232	RS-422	RS-485
1	DCD1	TXD422-	TXD485-
2	SIN1	TXD422+	TXD485+
3	SOUT1	RXD422+	
4	DTR1	RXD422-	
5	GND		
6	DSR1		
7	RTS1		
8	CTS1		
9	RI1		

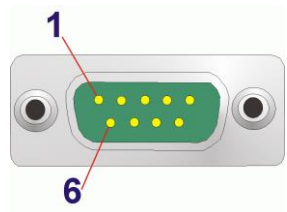


**Table 6-24: RS-232/422/485 DB-9 Serial Port (COM1) Pinouts**

**AFL3-W15C/W19C/W22C-ULT5 Panel PC**

**6.3.5 RS-232 RJ-45 Serial Port (COM2)**

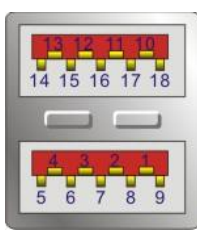
PIN NO.	DESCRIPTION	PIN NO.	DESCRIPTION
1	DCD2	6	DSR2
2	SIN2	7	RTS2
3	SOUT2	8	CTS2
4	RTS2	9	RI2
5	GND		



**Table 6-25: RS-232 RJ-45 Serial Port (COM2) Pinouts**

**6.3.6 USB 3.2 Gen 2 Connectors (USB\_CON1)**

PIN NO.	DESCRIPTION	PIN NO.	DESCRIPTION
1	USB_VCC	2	USB2_D0-
3	USB2_D0-	4	GND
5	USB3_RXD0-	6	USB3_RXD0+
7	GND	8	USB3_TXD0-
9	USB3_TXD0+	10	USB_VCC
11	USB2_D1-	12	USB2_D1+
13	GND	14	USB3_RXD1-
15	USB3_RXD1+	16	GND
17	USB3_TXD1-	18	USB3_TXD1+



**Table 6-26: USB 3.2 Gen 2 Connectors (USB\_CON1, USB\_CON2) Pinouts**

Appendix

**A**

# Regulatory Compliance

---



**DECLARATION OF CONFORMITY**

This equipment is in conformity with the following EU directives:

- EMC Directive (2014/30/EU)
- Low-Voltage Directive (2014/35/EU)
- RoHS II Directive (2011/65/EU, 2015/863/EU)

If the user modifies and/or install other devices in the equipment, the CE conformity declaration may no longer apply.

If this equipment has telecommunications functionality, it also complies with the requirements of the Radio Equipment Directive 2014/53/EU.

---

**English**

IEI Integration Corp declares that this equipment is in compliance with the essential requirements and other relevant provisions of Directive 2014/53/EU.

---

**Български [Bulgarian]**

IEI Integration Corp. декларира, че този оборудване е в съответствие със съществените изисквания и другите приложими правила на Директива 2014/53/EU.

---

**Česky [Czech]**

IEI Integration Corp tímto prohlašuje, že tento zařizení je ve shodě se základními požadavky a dalšími příslušnými ustanoveními směrnice 2014/53/EU.

---

**Dansk [Danish]**

IEI Integration Corp erklærer herved, at følgende udstyr overholder de væsentlige krav og øvrige relevante krav i direktiv 2014/53/EU.

---

**Deutsch [German]**

IEI Integration Corp, erklärt dieses Gerät entspricht den grundlegenden Anforderungen und den weiteren entsprechenden Vorgaben der Richtlinie 2014/53/EU.

---

**Eesti [Estonian]**

IEI Integration Corp deklareerib seadme seadme vastavust direktiivi 2014/53/EÜ põhinõuetele ja nimetatud direktiivist tulenevatele teistele asjakohastele sätetele.

---

---

**Español [Spanish]**

IEI Integration Corp declara que el equipo cumple con los requisitos esenciales y cualesquiera otras disposiciones aplicables o exigibles de la Directiva 2014/53/EU.

---

**Ελληνική [Greek]**

IEI Integration Corp ΔΗΛΩΝΕΙ ΟΤΙ ΕΞΟΠΛΙΣΜΟΣ ΣΥΜΜΟΡΦΩΝΕΤΑΙ ΠΡΟΣ ΤΙΣ ΟΥΣΙΩΔΕΙΣ ΑΠΑΙΤΗΣΕΙΣ ΚΑΙ ΤΙΣ ΛΟΙΠΕΣ ΣΧΕΤΙΚΕΣ ΔΙΑΤΑΞΕΙΣ ΤΗΣ ΟΔΗΓΙΑΣ 2014/53/EU.

---

**Français [French]**

IEI Integration Corp déclare que l'appareil est conforme aux exigences essentielles et aux autres dispositions pertinentes de la directive 2014/53/EU.

---

**Italiano [Italian]**

IEI Integration Corp dichiara che questo apparecchio è conforme ai requisiti essenziali ed alle altre disposizioni pertinenti stabilite dalla direttiva 2014/53/EU.

---

**Latviski [Latvian]**

IEI Integration Corp deklarē, ka iekārta atbilst būtiskajām prasībām un citiem ar to saistītajiem noteikumiem Direktīvas 2014/53/EU.

---

**Lietuvių [Lithuanian]**

IEI Integration Corp deklaruoja, kad šis įranga atitinka esminius reikalavimus ir kitas 2014/53/EU Direktyvos nuostatas.

---

**Nederlands [Dutch]**

IEI Integration Corp dat het toestel toestel in overeenstemming is met de essentiële eisen en de andere relevante bepalingen van richtlijn 2014/53/EU.

---

**Malti [Maltese]**

IEI Integration Corp jiddikjara li dan prodott jikkonforma mal-ħtiġijiet essenzjali u ma provvedimenti oħrajn relevanti li hemm fid-Dirrettiva 2014/53/EU.

---

**Magyar [Hungarian]**

IEI Integration Corp nyilatkozom, hogy a berendezés megfelel a vonatkozó alapvető követelményeknek és az 2014/53/EU irányelv egyéb előírásainak.

---

**Polski [Polish]**

IEI Integration Corp oświadcza, że wyrobu jest zgodny z zasadniczymi wymogami oraz pozostałymi stosownymi postanowieniami Dyrektywy 2014/53/EU.

---

**Português [Portuguese]**

IEI Integration Corp declara que este equipamento está conforme com os requisitos essenciais e outras disposições da Directiva 2014/53/EU.

---

## AFL3-W15C/W19C/W22C-ULT5 Panel PC

---

Româna [Romanian]

IEI Integration Corp declară că acest echipament este în conformitate cu cerințele esențiale și cu celelalte prevederi relevante ale Directivei 2014/53/EU.

---

Slovensko [Slovenian]

IEI Integration Corp izjavlja, da je ta opreme v skladu z bistvenimi zahtevami in ostalimi relevantnimi določili direktive 2014/53/EU.

---

Slovensky [Slovak]

IEI Integration Corp týmto vyhlasuje, že zariadenia spĺňa základné požiadavky a všetky príslušné ustanovenia Smernice 2014/53/EU.

---

Suomi [Finnish]

IEI Integration Corp vakuuttaa täten että laitteet on direktiivin 2014/53/EU oleellisten vaatimusten ja sitä koskevien direktiivin muiden ehtojen mukainen.

---

Svenska [Swedish]

IEI Integration Corp förklarar att denna utrustningstyp står i överensstämmelse med de väsentliga egenskapskrav och övriga relevanta bestämmelser som framgår av direktiv 2014/53/EU.

---

**FCC WARNING**

This equipment complies with Part 15 of the FCC Rules. Operation is subject to the following two conditions:

- This device may not cause harmful interference, and
- This device must accept any interference received, including interference that may cause undesired operation.

This equipment has been tested and found to comply with the limits for a Class A digital device, pursuant to part 15 of the FCC Rules. These limits are designed to provide reasonable protection against harmful interference when the equipment is operated in a commercial environment. This equipment generates, uses, and can radiate radio frequency energy and, if not installed and used in accordance with the instruction manual, may cause harmful interference to radio communications. Operation of this equipment in a residential area is likely to cause harmful interference in which case the user will be required to correct the interference at his own expense.

Any changes or modifications not expressly approved by the party responsible for compliance could void the user's authority to operate the equipment.

This equipment complies with FCC radiation exposure limits set forth for an uncontrolled environment. This equipment should be installed and operated with a minimum distance of 20cm between the radiator & your body.

**CHINA ROHS**

The label on the product indicates the estimated "Environmentally Friendly Use Period" (EFUP). This is an estimate of the number of years that these substances would "not leak out or undergo abrupt change." This product may contain replaceable sub-assemblies/components which have a shorter EFUP such as batteries and lamps. These components will be separately marked.

Appendix

**B**

# Safety Precautions

---



**WARNING:**

The precautions outlined in this chapter should be strictly followed. Failure to follow these precautions may result in permanent damage to the AFL3-W15C/W19C/W22C-ULT5.

## B.1 Safety Precautions

Please follow the safety precautions outlined in the sections that follow:

### B.1.1 General Safety Precautions

Please ensure the following safety precautions are adhered to at all times.

- **Follow the electrostatic precautions** outlined below whenever the device is opened.
- **Make sure the power is turned off and the power cord is disconnected** whenever the AFL3-W15C/W19C/W22C-ULT5 is being installed, moved or modified.
- **To prevent the risk of electric shock, make sure power cord is unplugged from wall socket.** To fully disengage the power to the unit, please disconnect the power cord from the AC outlet. Refer servicing to qualified service personnel. The AC outlet shall be readily available and accessible.
- **Do not apply voltage levels that exceed the specified voltage range.** Doing so may cause fire and/or an electrical shock. Use a power cord that matches the voltage of the power outlet, which has been approved and complies with the safety standard of your particular country.
- **Electric shocks can occur** if the AFL3-W15C/W19C/W22C-ULT5 chassis is opened when it is running. To avoid risk of electric shock, this device must only be connected to a supply mains with protective earth.
- **Do not drop or insert any objects** into the ventilation openings of the AFL3-W15C/W19C/W22C-ULT5.

## AFL3-W15C/W19C/W22C-ULT5 Panel PC

- ***If considerable amounts of dust, water, or fluids enter the device***, turn off the power supply immediately, unplug the power cord, and contact the AFL3-W15C/W19C/W22C-ULT5 vendor.
- ***This equipment is not suitable for use in locations where children are likely to be present.***
- **DO NOT:**
  - Drop the device against a hard surface.
  - Strike or exert excessive force onto the LCD panel.
  - Touch any of the LCD panels with a sharp object
  - In a site where the ambient temperature exceeds the rated temperature

### B.1.2 Anti-static Precautions

---



#### **WARNING:**

Failure to take ESD precautions during the installation of the AFL3-W15C/W19C/W22C-ULT5 may result in permanent damage to the AFL3-W15C/W19C/W22C-ULT5 and severe injury to the user.

---

Electrostatic discharge (ESD) can cause serious damage to electronic components, including the AFL3-W15C/W19C/W22C-ULT5. Dry climates are especially susceptible to ESD. It is therefore critical that whenever the AFL3-W15C/W19C/W22C-ULT5 is opened and any of the electrical components are handled, the following anti-static precautions are strictly adhered to.

- ***Wear an anti-static wristband:*** Wearing a simple anti-static wristband can help to prevent ESD from damaging any electrical component.
- ***Self-grounding:*** Before handling any electrical component, touch any grounded conducting material. During the time the electrical component is handled, frequently touch any conducting materials that are connected to the ground.
- ***Use an anti-static pad:*** When configuring or working with an electrical component, place it on an anti-static pad. This reduces the possibility of ESD damage.

- **Only handle the edges of the electrical component.** When handling the electrical component, hold the electrical component by its edges.

### B.1.3 Product Disposal

---

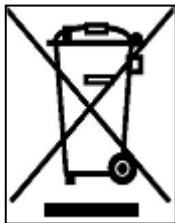


#### CAUTION:

Risk of explosion if the battery is replaced by an incorrect type;  
Replacement of a battery with an incorrect type that can defeat a safeguard (for example, in the case of some lithium battery types);  
Disposal of a battery into fire or a hot oven, or mechanically crushing or cutting of a battery, that can result in an explosion;  
Leaving a battery in an extremely high temperature surrounding environment that can result in an explosion or the leakage of flammable liquid or gas;  
A battery subjected to extremely low air pressure that may result in an explosion or the leakage of flammable liquid or gas;  
Dispose of used batteries according to instructions and local regulations.

---

- Outside the European Union–If you wish to dispose of used electrical and electronic products outside the European Union, please contact your local authority so as to comply with the correct disposal method.
- Within the European Union–The device that produces less waste and is easier to recycle is classified as electronic device in terms of the European Directive 2012/19/EU (WEEE), and must not be disposed of as domestic garbage.



EU-wide legislation, as implemented in each Member State, requires that waste electrical and electronic products carrying the mark (left) must be disposed of separately from normal household waste. This includes monitors and electrical accessories, such as signal cables or power cords. When you need to dispose of your display products, please follow the guidance of your local authority, or ask the shop where you purchased the product. The mark on electrical and electronic products only applies to the current European Union Member States.

Please follow the national guidelines for electrical and electronic product disposal.

## AFL3-W15C/W19C/W22C-ULT5 Panel PC

### B.2 Maintenance and Cleaning Precautions

When maintaining or cleaning the AFL3-W15C/W19C/W22C-ULT5, please follow the guidelines below.



#### **WARNING:**

- For safety reasons, turn-off the power and unplug the panel PC before cleaning.
  - If you dropped any material or liquid such as water onto the panel PC when cleaning, unplug the power cable immediately and contact your dealer or the nearest service center. Always make sure your hands are dry when unplugging the power cable.
- 

#### B.2.1 Maintenance and Cleaning

Prior to cleaning any part or component of the AFL3-W15C/W19C/W22C-ULT5, please read the details below.

- Except for the LCD panel, never spray or squirt liquids directly onto any other components. To clean the LCD panel, gently wipe it with a piece of soft dry cloth or a slightly moistened cloth.
- The interior of the device does not require cleaning. Keep fluids away from the device interior.
- Be cautious of all small removable components when vacuuming the device.
- Never drop any objects or liquids through the openings of the device.
- Be cautious of any possible allergic reactions to solvents or chemicals used when cleaning the device.
- Avoid eating, drinking and smoking within vicinity of the device.

#### B.2.2 Cleaning Tools

Some components in the AFL3-W15C/W19C/W22C-ULT5 may only be cleaned using a product specifically designed for the purpose. In such case, the product will be explicitly mentioned in the cleaning tips. Below is a list of items to use when cleaning the AFL3-W15C/W19C/W22C-ULT5.

- **Cloth**– Although paper towels or tissues can be used, a soft, clean piece of cloth is recommended when cleaning the device.
- **Water or rubbing alcohol**–A cloth moistened with water or rubbing alcohol can be used to clean the device.
- **Using solvents**–The use of solvents is not recommended when cleaning the device as they may damage the plastic parts.
- **Vacuum cleaner**–Using a vacuum specifically designed for computers is one of the best methods of cleaning the device. Dust and dirt can restrict the airflow in the device and cause its circuitry to corrode.
- **Cotton swabs**–Cotton swaps moistened with rubbing alcohol or water are excellent tools for wiping hard to reach areas.
- **Foam swabs**–Whenever possible, it is best to use lint free swabs such as foam swabs for cleaning.



Appendix

C

# BIOS Menu Options

---

System Date [xx/xx/xx] .....	56
System Time [xx:xx:xx] .....	56
Intel® (VMX) Virtualization Technology [Disabled] .....	57
Active Processor Cores [All] .....	58
Hyper-threading [Enabled].....	58
Intel® SpeedStep™ [Enabled] .....	58
C State [Disabled] .....	58
Unconfigure ME [Disabled] .....	59
ACPI Sleep State [S3 (Suspend to RAM)].....	60
Wake system with Fixed Time [Disabled].....	61
PC Health Status .....	62
Serial Port [Enabled].....	64
Device Mode [RS232].....	64
Serial Port [Enabled].....	65
Console Redirection [Disabled] .....	66
Legacy Serial Redirection Port [COM1].....	66
Terminal Type [ANSI].....	67
Bits per second [115200].....	68
Data Bits [8] .....	68
Parity [None].....	68
Stop Bits [1].....	69
USB Devices .....	69
Legacy USB Support [Enabled].....	70
Auto Recovery Function [Disabled].....	71
VT-d [Disabled].....	73
Fast Boot [Enabled].....	73
DVMT Pre-Allocated [32M] .....	74
DVMT Total Gfx Mem [MAX].....	74
Primary IGFX Boot Display [VBIOS Default] .....	75
Backlight Control [LED] .....	75
Restore AC Power Loss [Last State] .....	76
Power Saving Function(ERP) [Disabled].....	76
HD Audio [Enabled] .....	76
USB Power SW [+5V DUAL].....	76
M2_A1 / MINI_PCIE1 / M2_M2 [Enabled].....	77

## AFL3-W15C/W19C/W22C-ULT5 Panel PC

PCIe Speed [Auto].....	77
Detect Non-Compliance Device [Disabled] .....	78
STAT Controller(s) [Enabled].....	78
SATA Mode Selection [AHCI].....	79
PCIe Storage Dev On Port M2_M2 [Not RST Controlled].....	79
Administrator Password .....	80
User Password .....	80
Bootup NumLock State [On].....	81
Quiet Boot [Enabled] .....	82
Launch PXE OpROM [Disabled] .....	82
Option ROM Messages [Force BIOS].....	82
UEFI Boot [Disabled] .....	82
Boot Option Priority.....	82
Save Changes and Reset .....	83
Discard Changes and Reset .....	83
Restore Defaults .....	83
Save as User Defaults .....	84
Restore User Defaults .....	84

Appendix

**D**

# Watchdog Timer

---

**NOTE:**

The following discussion applies to DOS. Contact IEI support or visit the IEI website for drivers for other operating systems.

The Watchdog Timer is a hardware-based timer that attempts to restart the system when it stops working. The system may stop working because of external EMI or software bugs. The Watchdog Timer ensures that standalone systems like ATMs will automatically attempt to restart in the case of system problems.

A BIOS function call (INT 15H) is used to control the Watchdog Timer.

INT 15H:

<b>AH – 6FH Sub-function:</b>	
AL – 2:	Sets the Watchdog Timer's period.
BL:	Time-out value (Its unit-second is dependent on the item "Watchdog Timer unit select" in CMOS setup).

**Table D-1: AH-6FH Sub-function**

Call sub-function 2 to set the time-out period of Watchdog Timer first. If the time-out value is not zero, the Watchdog Timer starts counting down. When the timer value reaches zero, the system resets. To ensure that this reset condition does not occur, calling sub-function 2 must periodically refresh the Watchdog Timer. However, the watchdog timer is disabled if the time-out value is set to zero.

A tolerance of at least 10% must be maintained to avoid unknown routines within the operating system (DOS), such as disk I/O that can be very time-consuming.



**NOTE:**

The Watchdog Timer is activated through software. The software application that activates the Watchdog Timer must also deactivate it when closed. If the Watchdog Timer is not deactivated, the system will automatically restart after the Timer has finished its countdown.

**EXAMPLE PROGRAM:**

**; INITIAL TIMER PERIOD COUNTER**

;

**W\_LOOP:**

;

```
MOV     AX, 6F02H      ;setting the time-out value
MOV     BL, 30         ;time-out value is 48 seconds
INT     15H
```

;

**; ADD THE APPLICATION PROGRAM HERE**

;

```
CMP     EXIT_AP, 1     ;is the application over?
JNE     W_LOOP        ;No, restart the application
```

```
MOV     AX, 6F02H      ;disable Watchdog Timer
MOV     BL, 0         ;
INT     15H
```

;

**; EXIT ;**

Appendix

**E**

# Error Beep Code

---

### E.1 PEI Beep Codes

Number of Beeps	Description
1	Memory not Installed
1	Memory was installed twice (InstallPeiMemory routine in PEI Core called twice)
2	Recovery started
3	DXE IPL was not found
3	DXE Core Firmware Volume was not found
4	Recovery failed
4	S3 Resume failed
7	Reset PPI is not available

### E.2 DXE Beep Codes

Number of Beeps	Description
1	Invalid password
4	Some of the Architectural Protocols are not available
5	No Console Output Devices are found
5	No Console Input Devices are found
6	Flash update is failed
7	Reset protocol is not available
8	Platform PCI resource requirements cannot be met



**NOTE:**

If you have any question, please contact IEI for further assistance.

Appendix

F

# Hazardous Materials Disclosure

---

### F.1 RoHS II Directive (2015/863/EU)

The details provided in this appendix are to ensure that the product is compliant with the RoHS II Directive (2015/863/EU). The table below acknowledges the presences of small quantities of certain substances in the product, and is applicable to RoHS II Directive (2015/863/EU).

Please refer to the following table.

Part Name	Toxic or Hazardous Substances and Elements									
	Lead (Pb)	Mercury (Hg)	Cadmium (Cd)	Hexavalent Chromium (CR(VI))	Polybrominated Biphenyls (PBB)	Polybrominated Diphenyl Ethers (PBDE)	Bis(2-ethylhexyl) phthalate (DEHP)	Butyl benzyl phthalate (BBP)	Dibutyl phthalate (DBP)	Diisobutyl phthalate (DIBP)
Housing	O	O	O	O	O	O	O	O	O	O
Printed Circuit Board	O	O	O	O	O	O	O	O	O	O
Metal Fasteners	O	O	O	O	O	O	O	O	O	O
Cable Assembly	O	O	O	O	O	O	O	O	O	O
Fan Assembly	O	O	O	O	O	O	O	O	O	O
Power Supply Assemblies	O	O	O	O	O	O	O	O	O	O
Battery	O	O	O	O	O	O	O	O	O	O
<p>O: This toxic or hazardous substance is contained in all of the homogeneous materials for the part is below the limit requirement in Directive (EU) 2015/863.</p> <p>X: This toxic or hazardous substance is contained in at least one of the homogeneous materials for this part is above the limit requirement in Directive (EU) 2015/863.</p>										



## AFL3-W15C/W19C/W22C-ULT5 Panel PC

### F.2 China RoHS

此附件旨在确保本产品符合中国 RoHS 标准。以下表格标示此产品中某有毒物质的含量符合中国 RoHS 标准规定的限量要求。

本产品上会附有“环境友好使用期限”的标签，此期限是估算这些物质“不会有泄漏或突变”的年限。本产品可能包含有较短的环境友好使用期限的可替换元件，像是电池或灯管，这些元件将会单独标示出来。

部件名称	有毒有害物质或元素					
	铅 (Pb)	汞 (Hg)	镉 (Cd)	六价铬 (CR(VI))	多溴联苯 (PBB)	多溴二苯醚 (PBDE)
壳体	○	○	○	○	○	○
印刷电路板	○	○	○	○	○	○
金属螺帽	○	○	○	○	○	○
电缆组装	○	○	○	○	○	○
风扇组装	○	○	○	○	○	○
电力供应组装	○	○	○	○	○	○
电池	○	○	○	○	○	○

○: 表示该有毒有害物质在该部件所有物质材料中的含量均在 SJ/T11364-2014 與 GB/T26572-2011 标准规定的限量要求以下。

X: 表示该有毒有害物质至少在该部件的某一均质材料中的含量超出 SJ/T11364-2014 與 GB/T26572-2011 标准规定的限量要求。